

F Series Commercial Units

- Tailored solutions between 250 and 3,250 CFM
- Indoor and rooftop versions available
- Internal fans standard
- Heavy-duty steel construction
- Wide variety of options available for customized solutions
- AHRI Certified C510 Core

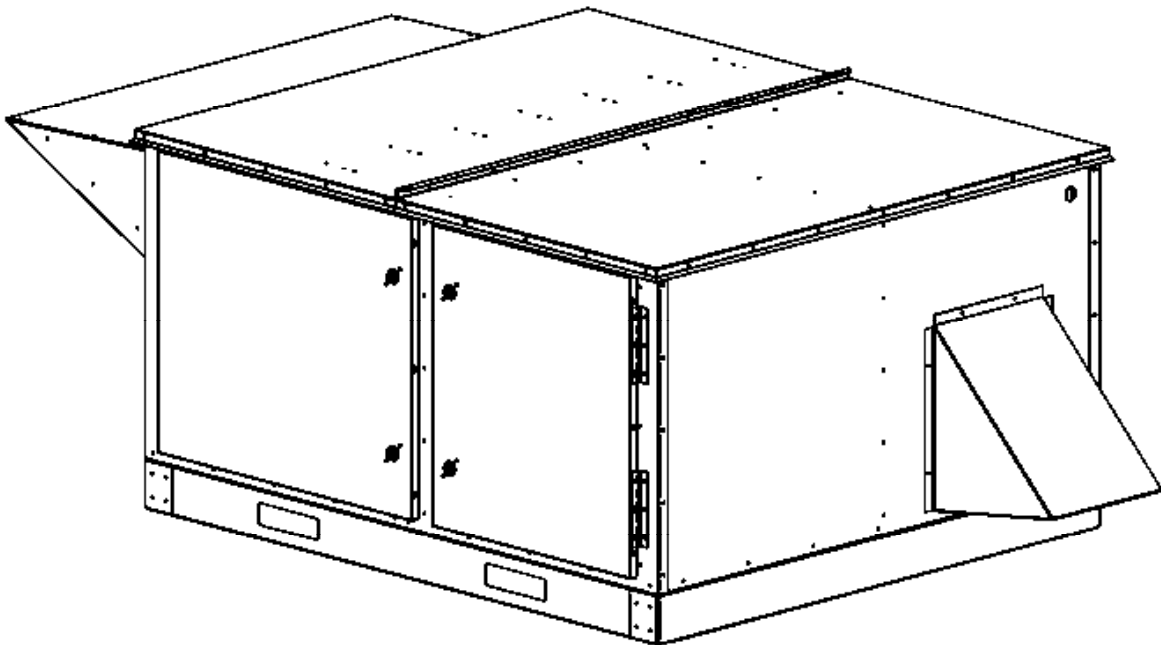

Breakthrough technology...

Dais Analytic Corporation manufactures and sells the high performance ConsERV™ energy recovery ventilation system we introduced in 2002. Our patented polymer materials, grown out of space-age fuel cell research, are the key component of our revolutionary ConsERV™ air-to-air fixed-plate enthalpy exchangers. These unique materials provide the technology breakthrough that brings our customers unprecedented performance and energy savings in a reliable fixed-plate design.

An energy recovery ventilator (“ERV”) features a heat exchanger combined with ventilation to provide pre-conditioned air into a building. Pre-conditioning the air saves energy – and money – by reducing the load on your HVAC system. During the summer, outside air is cooled and dehumidified before it enters the building and your air conditioning system. During winter, the opposite occurs as the outside air is heated and humidified by the outgoing exhaust air. In most applications, both sensible heat transfer (temperature exchange) and latent heat transfer (moisture exchange) within the exchanger are desired. Until now, energy recovery wheels have been the principal means of providing this total energy transfer, since fixed plate products did not have the ability to transfer latent heat very well.

Enter Dais Analytic. Dais has developed the ConsERV™ energy exchanger, which transfers high levels of both sensible and latent heat and can reduce energy consumption and HVAC loads from fresh air ventilation by up to 80%. No rotating or moving parts in the exchanger mean less energy consumption by the ERV, lower maintenance costs, and peace of mind when downsizing HVAC equipment capacity.

Our ConsERV™ exchanger doesn't depend on open pores or fragile surface-mounted desiccants to transfer water from one air stream to the other. Instead, the polymer separating the air streams is organized at a nanometer level to create highly charged regions that draw water molecules into the material. There is no physical opening, so the polymer is hermetic and prevents crossover of air molecules. The water molecules move easily between charges along the polymer backbone, passing through the material from the side with higher vapor pressure to the side with lower vapor pressure.

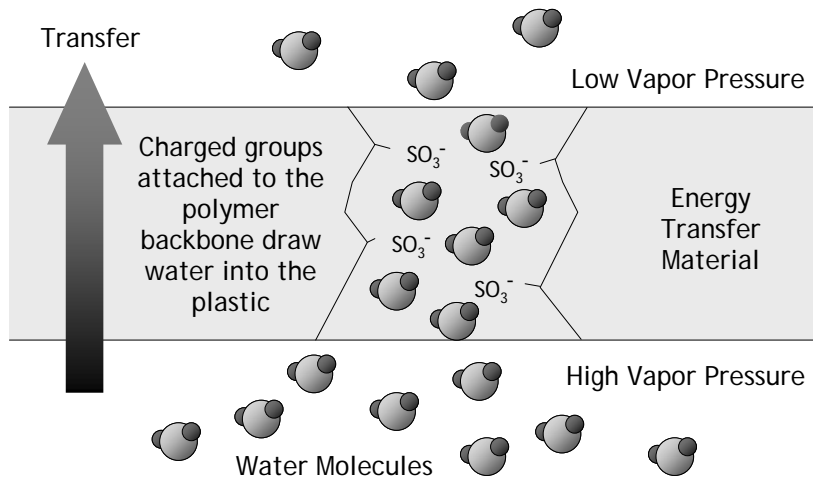

About ConsERV™ ...

Offering energy savings, rapid return on investment, and ease of use to consumers by pre-treating ventilation air.

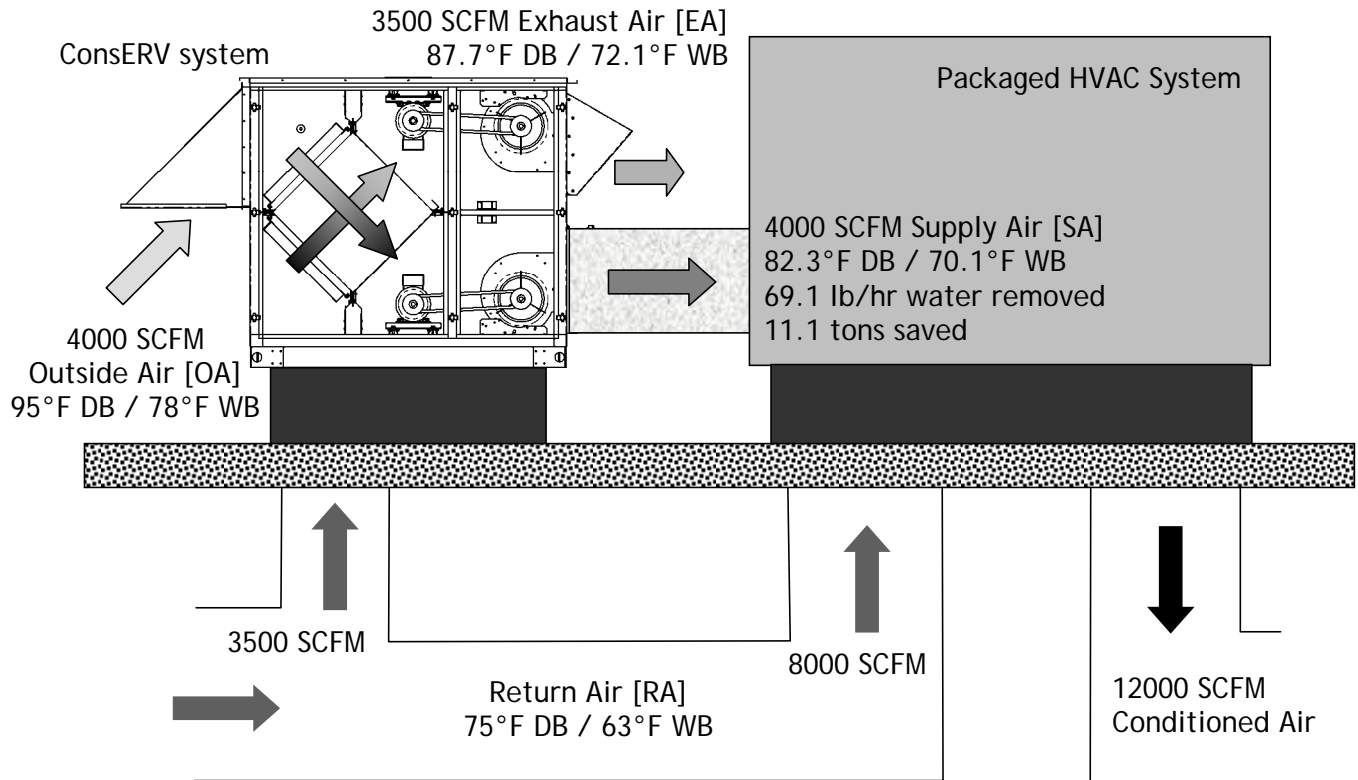

Example: D8R-FSE-xSHHVH system operating at AHRI Cooling conditions

Features and Benefits:

- Advanced materials = highest latent and total effectiveness of any fixed plate ERV
- No moving parts eliminates the most costly maintenance
- Savings of up to 30% on installed HVAC capital costs and up to 50% on operating costs
- Failsafe operation - transfers energy as long as there is airflow
- Reliability allows safer downsizing of attached HVAC equipment.
- Zero air stream leakage - core does not allow cross contamination
- No defrost needed in most climate zones
- Equally effective in both summer and winter = year-round savings
- Water stays in vapor phase = no liquid water
- Light, corrosion-resistant aluminum cabinets offer double wall construction, 6.3 R-value
- Steel cabinets offer single or double wall options
- Industry standard electrical and monitoring options
- Easy installation with flexible air flow configurations and a smaller installed footprint

Certifications and Awards:

- UL 900 Recognized
- AHRI 1060 certified performance
- 2006 AHR Ventilation Innovation Award winner

Our Products...

F Series (Steel construction)

F Series ConsERV™ systems are constructed of galvanized steel and provide a very cost effective solution. This unit utilizes our latest AHRI certified C510 core. This core/box combination provides both indoor and rooftop units with a number of air flow direction combinations. We offer a low profile single row version option which handles 250-3,250 CFM and is only 27" tall for indoor version and 30" for the rooftop version. For CFM ranges greater than 3,250 CFM use the double row version. The units are designed to offer a number of options including:

- Double walled cabinet
- Motorized dampers
- Fused or switched disconnects
- CO2 detection
- Filter maintenance indicator
- Low temperature lockout
- Motor maintenance indicator

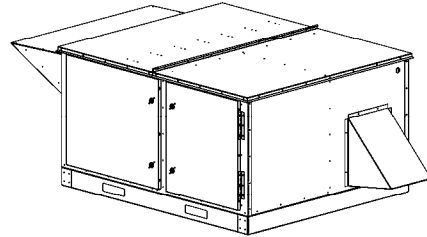

These units are equipped with a belt and pulley motor/fan assembly and have adjustability in air flow controlled by the sheave size selected.

C Series (Steel construction)

C Series ConsERV™ systems are constructed with a robust galvanized steel structure and offer a wide variety of accessories and options, all tied together by a powerful integrated control system. Units can be used both indoors and outdoors and are designed to mate easily with a large range of commercial package units.

Most units come standard with VFD-controlled fans for easy adjustment of the flow. An optional integrated VFD control system allows the user to specify a desired flow rate in CFM using an external display and the unit will maintain that value even as filters accumulate dirt or conditions change.

A large range of options are available, including:

- Motorized dampers
- Economizers
- Filter maintenance indicators
- Motor maintenance indicators
- Frost protection
- Low temperature lockout

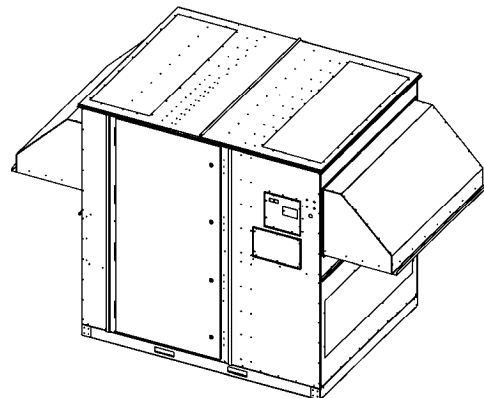

Our Products...

 **Product Comparison**

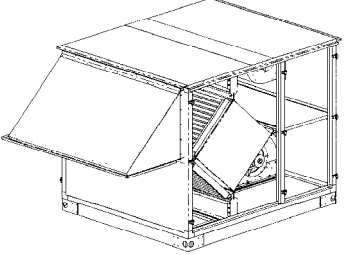
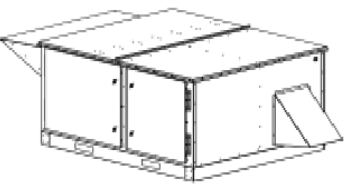
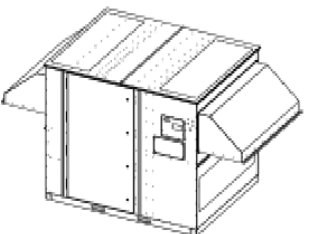
	D Series	F Series	C Series
Configuration			
Capacity	500 - 5,400 CFM	250 - 3,250 CFM	900 - 10,800 CFM
Core Type	C500S	C510	C500S
Construction	Aluminum frame and panels	Galvanized steel panels (painted steel available)	Galvanized steel panels (painted steel available)
Indoor / Outdoor	Indoor and outdoor versions available	Indoor and outdoor versions available	Indoor and outdoor versions available
Fan System	Belt and pulley centrifugal fan and motor assembly Non-fanned boxes available	Belt and pulley centrifugal fan and motor assembly	Direct-drive forward curved motorized impellers
Speed Control	VFD option available	N/A	Potentiometer speed control standard
Available Options			
Motorized Dampers		√	√
Double walled	Standard	√	√
14" curb	√	√	√
Pre Heat			Coming Soon
Disconnects	√	√	√
CO2 Sensor	√	√	√
Dirty Filter Indicator	√	√	√
Motor Indicator		√	√
Low Temp Lockout		√	√
Frost Protection	√	√	√
Timer	√	√	√

F Series Flow Configuration Examples

F Series units have many combinations of flow configurations including the examples below:

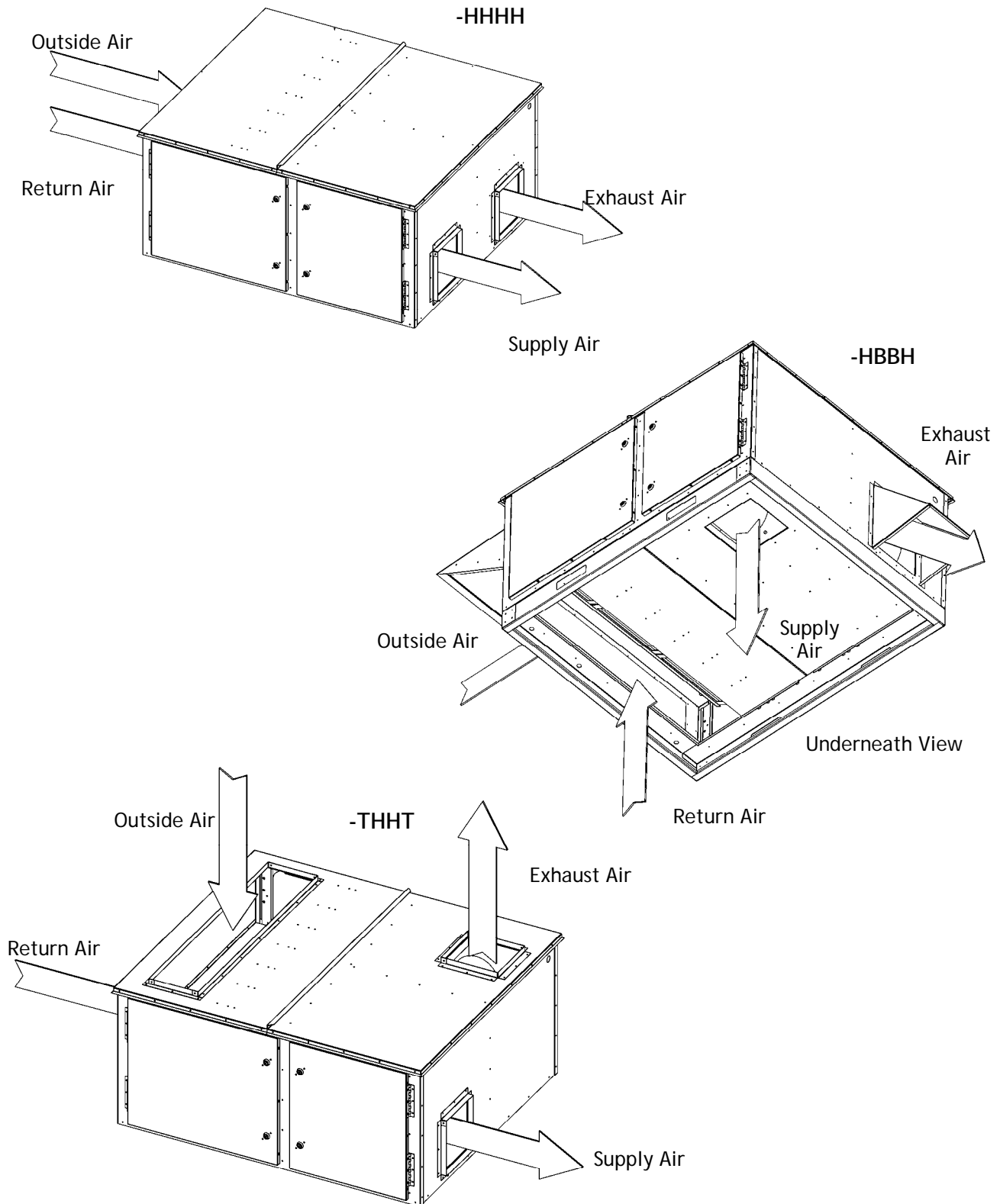

F02x-F06x Electrical

All F02x-F06x units use a belt and pulley system for the fresh air and exhaust air fans. Each box size has a standard (S) and a high static (H) option for each fan. The fan system used can be determined from the fan curves on page 49.

The F02x-F06x Series System can be wired for either Single-Phase or Three-Phase.

Model	Motor Configuration	208V / 1 ϕ			208V / 3 ϕ			230V / 1 ϕ			230V / 3 ϕ			460V / 3 ϕ			575V / 3 ϕ		
		FLA	MCA	MOP	FLA	MCA	MOP	FLA	MCA	MOP	FLA	MCA	MOP	FLA	MCA	MOP	FLA	MCA	MOP
F02x S = 1 HP H = 2 HP	F02x-SS	18.0	22.5	29.0	9.4	11.8	15.2	16.3	20.4	26.3	8.6	10.7	13.8	4.3	5.4	6.9	3.5	4.3	5.6
	F02x-HH	26.8	33.5	43.3	15.2	19.0	24.6	24.3	30.4	39.3	13.8	17.2	22.3	6.9	8.6	11.1	5.5	6.8	8.9
	F02x-SH (or HS)	22.4	28.0	38.9	12.3	15.4	21.7	20.3	25.4	35.3	11.2	14.0	19.7	5.6	7.0	9.8	4.5	5.6	7.9
F03x S = 2 HP H = 2 HP	F03x-SS	26.8	33.5	43.3	15.2	19.0	24.6	24.3	30.4	39.3	13.8	17.2	22.3	6.9	8.6	11.1	5.5	6.8	8.9
	F03x-HH	26.8	33.5	43.3	15.2	19.0	24.6	24.3	30.4	39.3	13.8	17.2	22.3	6.9	8.6	11.1	5.5	6.8	8.9
	F03x-SH (or HS)	26.8	33.5	43.3	15.2	19.0	24.6	24.3	30.4	39.3	13.8	17.2	22.3	6.9	8.6	11.1	5.5	6.8	8.9
F04x S = 2 HP H = 3 HP	F04x-SS	26.8	33.5	43.3	15.2	19.0	24.6	24.3	30.4	39.3	13.8	17.2	22.3	6.9	8.6	11.1	5.5	6.8	8.9
	F04x-HH	34.3	42.9	55.6	21.4	26.8	34.7	34.3	42.9	55.6	19.4	24.2	31.4	9.7	12.1	15.7	7.9	9.8	12.8
	F04x-SH (or HS)	32.3	40.3	55.6	18.3	22.9	31.6	29.3	36.7	50.6	16.6	20.7	28.6	8.3	10.4	14.3	6.7	8.3	11.6
F05x S = 3 HP H = 3 HP	F05x-SS	34.3	42.9	55.6	21.4	26.8	34.7	34.3	42.9	55.6	19.4	24.2	31.4	9.7	12.1	15.7	7.9	9.8	12.8
	F05x-HH	34.3	42.9	55.6	21.4	26.8	34.7	34.3	42.9	55.6	19.4	24.2	31.4	9.7	12.1	15.7	7.9	9.8	12.8
	F05x-SH (or HS)	34.3	42.9	55.6	21.4	26.8	34.7	34.3	42.9	55.6	19.4	24.2	31.4	9.7	12.1	15.7	7.9	9.8	12.8
F06x S = 3 HP H = 3 HP	F06x-SS	34.3	42.9	55.6	21.4	26.8	34.7	34.3	42.9	55.6	19.4	24.2	31.4	9.7	12.1	15.7	7.9	9.8	12.8
	F06x-HH	34.3	42.9	55.6	21.4	26.8	34.7	34.3	42.9	55.6	19.4	24.2	31.4	9.7	12.1	15.7	7.9	9.8	12.8
	F06x-SH (or HS)	34.3	42.9	55.6	21.4	26.8	34.7	34.3	42.9	55.6	19.4	24.2	31.4	9.7	12.1	15.7	7.9	9.8	12.8

Single-Phase

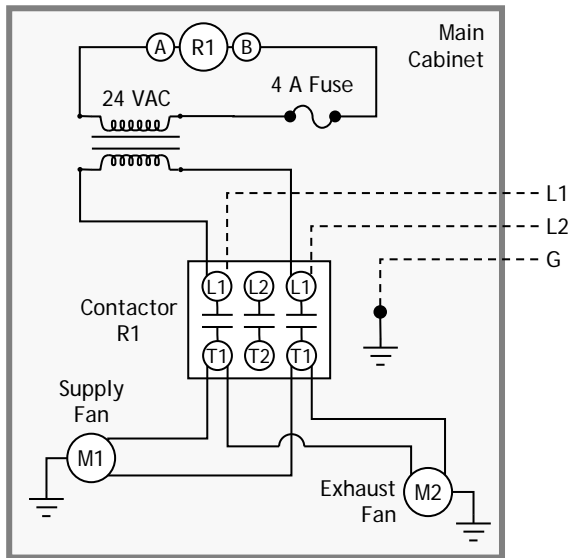

Three-Phase

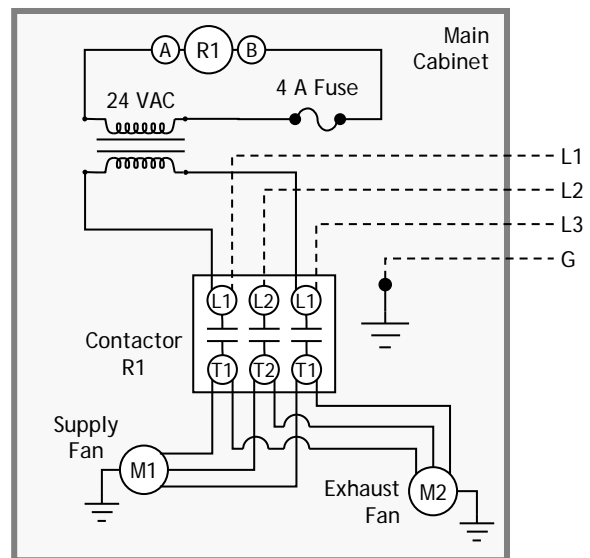

F Series Options (for F02x-F06x)

Electrical Disconnects

Factory installed electrical disconnects are available for all ERV units. Disconnects are sized to handle the ERV unit and pre-heater (when ordered together). Both switched and fused disconnects are available.

Motorized Dampers

Two position motorized outside air and exhaust air dampers are available to eliminate the migration of unwanted outside air into the building space when the ERV unit is off. Motors are 24 volt and are factory installed and wired. Outside air and exhaust air dampers are ordered separately.

ERV Control Timers

If the ERV unit is to be activated at only certain times of the day or week, an ERV control timer option should be ordered. Set timer to planned occupancy periods. Two types are available; the 24 volt timer is factory installed in the ERV unit while the 115 volt timer is to be field mounted and wired.

CO₂ Sensor

CO₂ sensors measure the carbon dioxide level in the space and activates the ERV unit at a predetermined setpoint. Wall mount and duct mount sensors are available.

Airflow Monitoring

Airflow monitoring gauges measure the outside air intake and exhaust air pressure across the ConsERV™ core. This allows for easier setup, balancing and monitoring.

Frost Protection

Applications with extremely cold climates may use the frost protection option as a means of eliminating frost build up on the ConsERV™ core. When frost builds up on the ConsERV™ core, the outside air blower is temporarily shut off and the warmer exhaust air “defrosts” the core. Once the frost build up is eliminated, the outside air blower is reactivated. Note: frost protection is not recommended on units with pre-heaters.

Low Temperature Lockout

For applications where the ERV unit is to be locked out in extremely cold temperatures, the low temperature lockout option should be used. When outside air temperature is below set point the ERV unit is completely shutdown. Thermostat range goes down to minus 30 degrees F.

ERV Filter Maintenance Indicator Switch

Senses static pressure across outside air intake filters. Rising static pressure indicates filters need service. Connect to field supplied 24 volt indicator light.

NOTE: By request, the indicator can be set up for the return air filters (contact factory).

F Series Curb

Roof Curbs

The ERV roof curbs are constructed of heavy gauge galvanized steel, and include a wood nailer and gasket package for a tight unit-to-curb seal. Standard curbs are 14" tall and are manufactured to NRCA specifications. Duct work can slide into the supply and return openings and hang from the top of the curb. Insulated deck pans and duct supports are provided. Vibration isolation curbs are available with 2" deflection springs and are shipped fully assembled.

NOTES:

- STANDARD 14" TALL FLAT-ROOF CURB
- 18 GA. GALVANIZED STEEL CONSTRUCTION
- KNOCKDOWN CURB, SHIPPED DISASSEMBLED
- FULL PERIMETER WOOD NAILER IS PROVIDED
- 0.25" x 1.50" FOAM GASKET TAPE IS PROVIDED

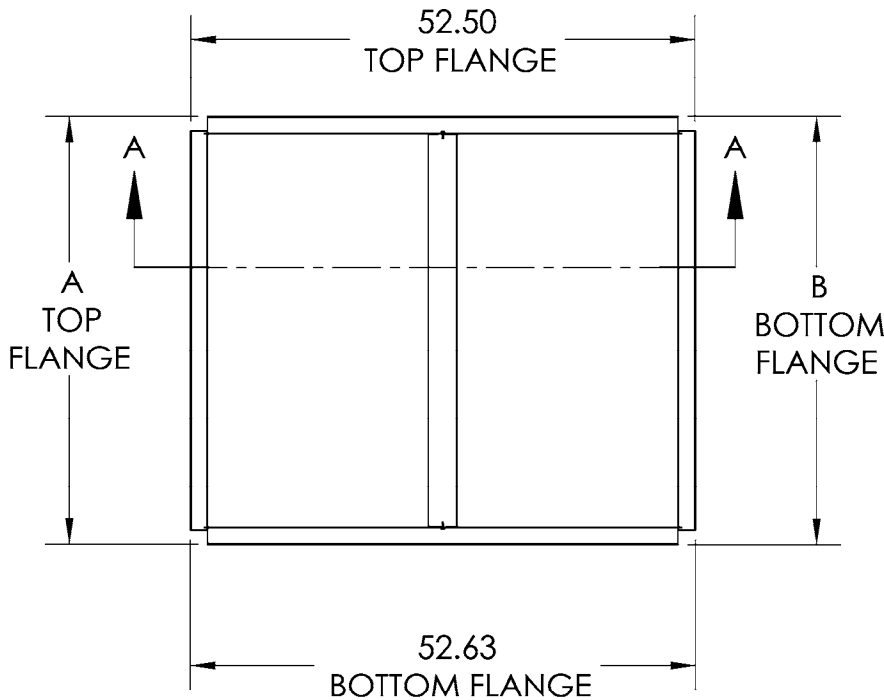
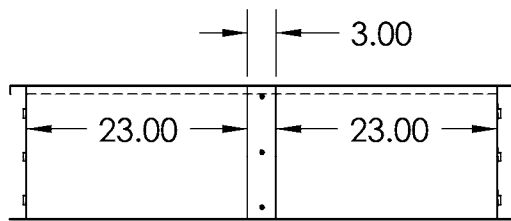
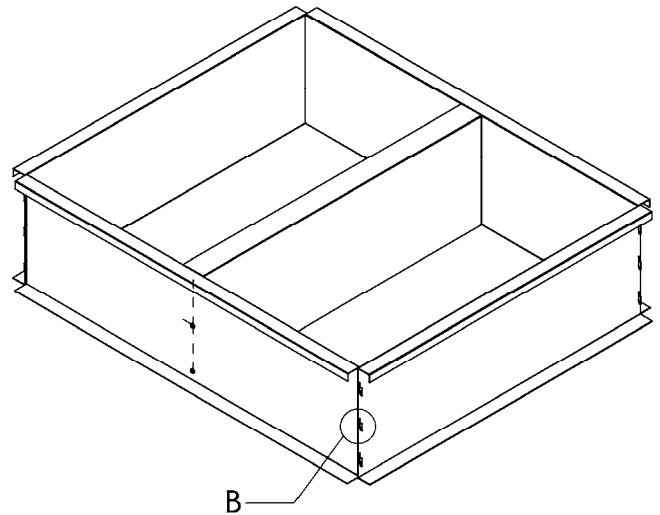

UNIT	A	B
F02R	28.75	28.88
F03R	44.5	44.63
F04R	60.25	60.38
F05R	76.00	76.13
F06R	91.75	91.88

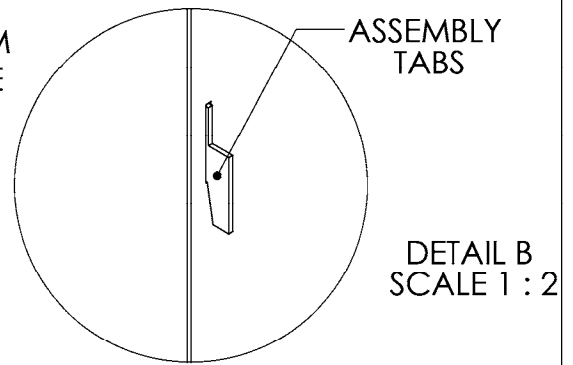

F02x - F06x Systems

F02x to F06x systems offer 2 to 6 C510 high-performance enthalpy exchange Conserv™ cores, making them suitable for flows ranging from 200 CFM to 3,500 CFM.

F02 - F06 Model Number Key		F	-	-	-	-	-	-	-	-	-	-	-
F = F series	Overall system type												
02 thru 06	# of C510 cores in system												
i = Indoor R = Rooftop	Installation location												
S = Standard H = High Static	Supply blower capability												
S = Standard H = High Static	Return blower capability												
1 = 115 V 2 = 208 V or 230 V 4 = 460 V 5 = 575 V	Electrical voltage												
1 = Single phase 3 = Three phase	Electrical service												
H = Horizontal T = Top	Outside Air [OA] entrance direction												
H = Horizontal T = Top B = Bottom	Supply Air [SA] exit direction												
H = Horizontal B = Bottom	Return Air [RA] entrance direction												
H = Horizontal T = Top B = Bottom	Exhaust Air [EA] exit direction												

Example: F03i-SS23-HHHH

This unit has 3 C510 cores for indoor installation. Both air streams use standard impellers, the power supply is 208 - 230V/3 ϕ , and all of the duct openings are in the horizontal direction.

F02x - F06x Systems

All F02x thru F06x systems are equipped with a belt and pulley centrifugal fan / motor assembly. If the standard operating envelope is not sufficient, each unit has a high static pressure option available as a factory option.

Model	Static Pressure Option	Motor HP	Fan RPM Range
F02x	Standard	1 HP	1333 - 1750
	High Static	2 HP	1703 - 2176
F03x	Standard	2 HP	1182 - 1577
	High Static	2 HP	1577 - 2160
F04x	Standard	2 HP	1232 - 1650
	High Static	3 HP	1400 - 1825
F05x	Standard	3 HP	853 - 1150
	High Static	3 HP	1150 - 1550
F06x	Standard	3 HP	877 - 1169
	High Static	3 HP	1053 - 1425

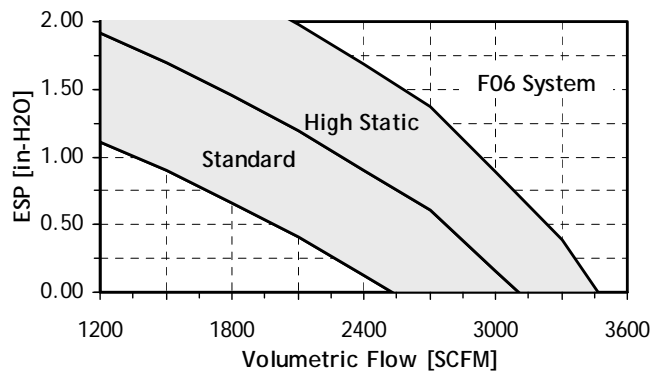
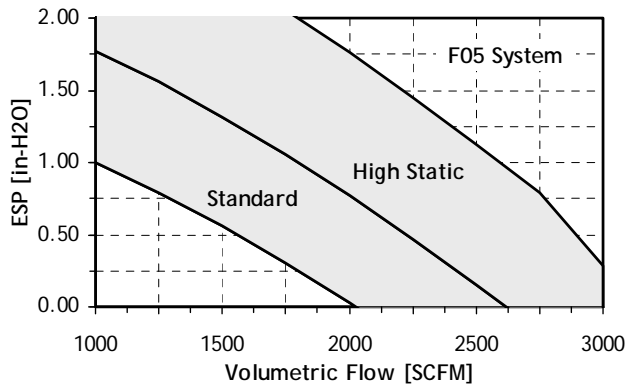
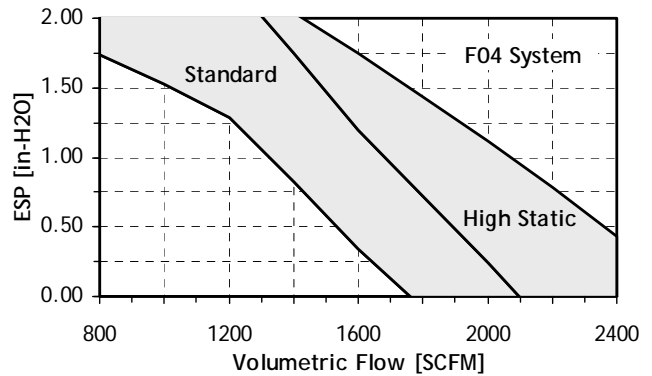
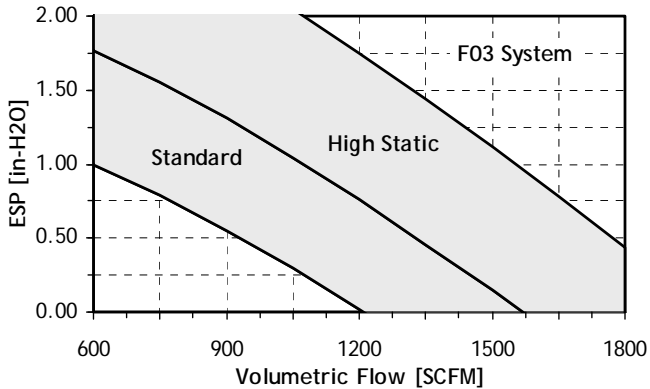
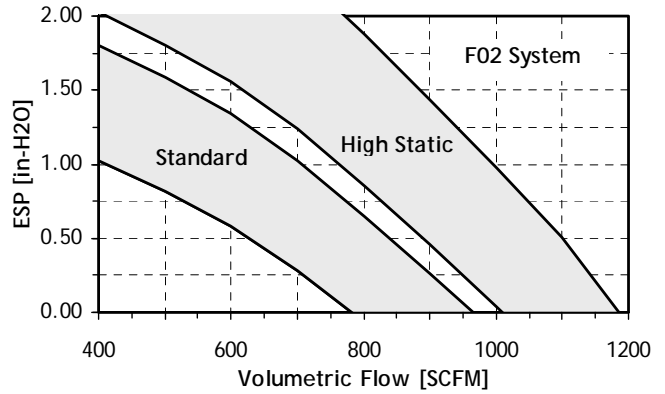

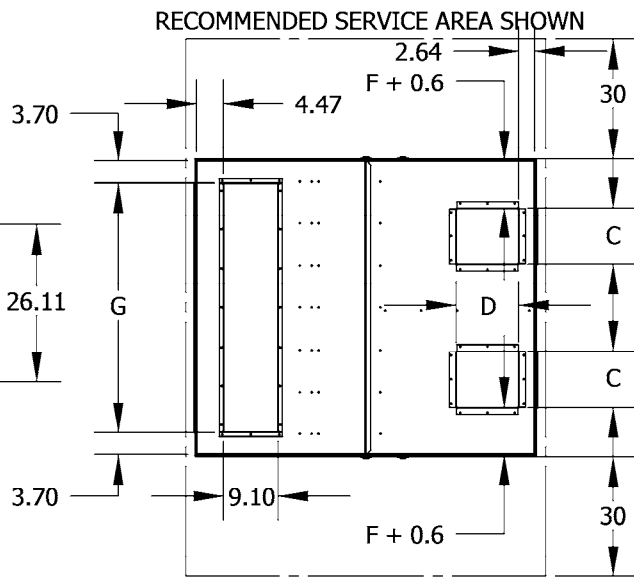
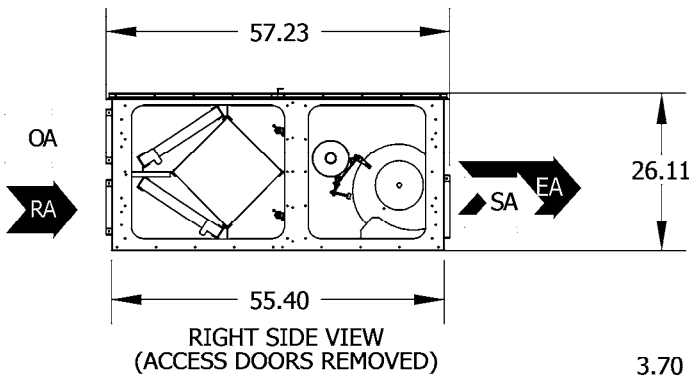
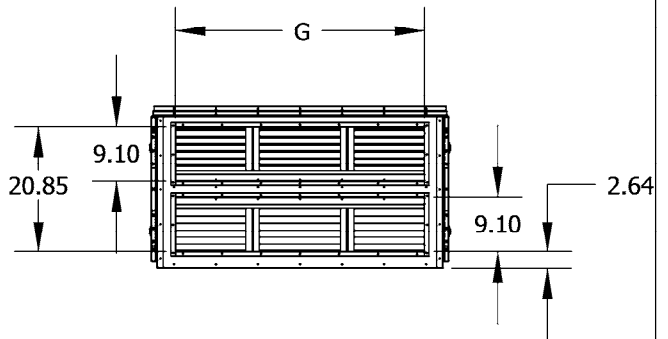
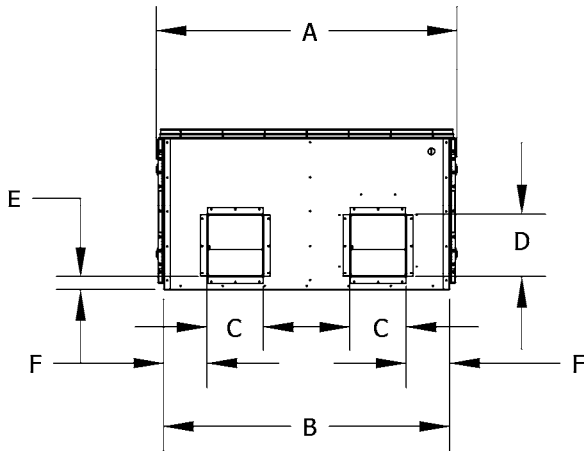
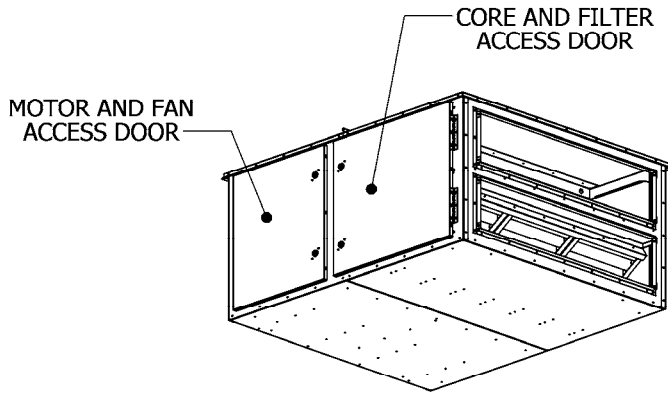
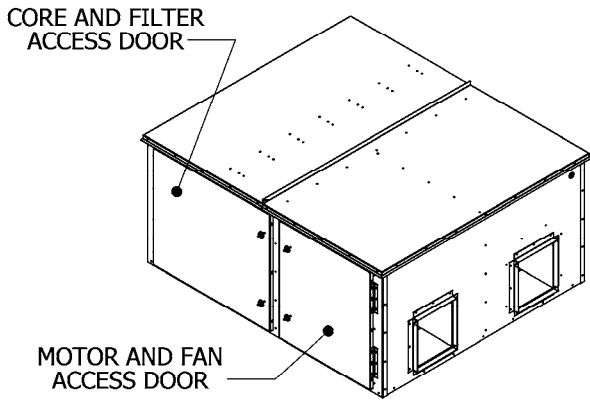

TOP VIEW
(OPTIONAL TOP DUCT CONNECTIONS SHOWN,
BOTTOM CONNECTIONS ARE SAME SIZE)

NOTES:

SYSTEM IS INTENDED FOR INDOOR USE ONLY

OA - OUTSIDE AIR INTAKE
SA - SUPPLY AIR EXIT
RA - RETURN AIR INTAKE
EA - EXHAUST AIR EXIT

OA & RA INPUTS CAN BE SWITCHED UPON REQUEST,
CAUSING SA & EA TO REVERSE POSITIONS

F03i MODEL PICTURED

CORES	MODEL #	WEIGHT [LB]	A	B	C	D	E	F	G
2	F02i	415	34.36	31.89	9.46	10.42	2.10	3.32	25.79
3	F03i	490	50.11	47.64	9.46	10.42	2.12	7.25	41.54
4	F04i	585	65.86	63.39	13.39	11.55	2.60	9.23	57.29
5	F05i	655	81.61	79.14	15.94	13.66	2.10	11.89	73.04
6	F06i	730	97.36	94.89	15.94	13.66	2.08	15.82	88.79

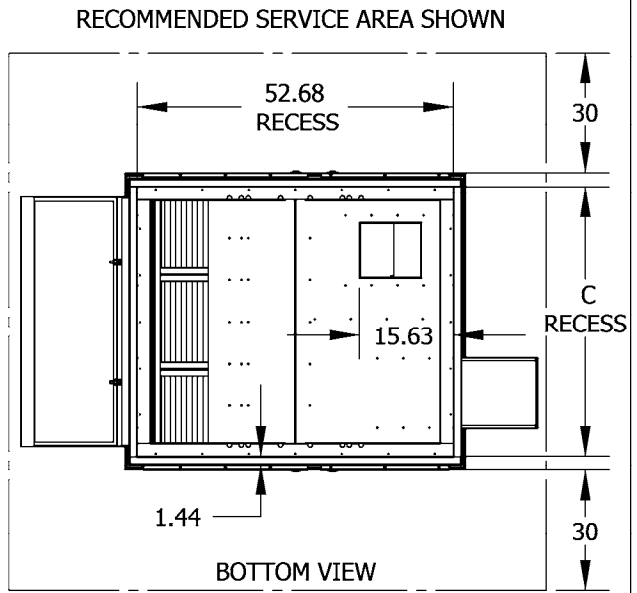
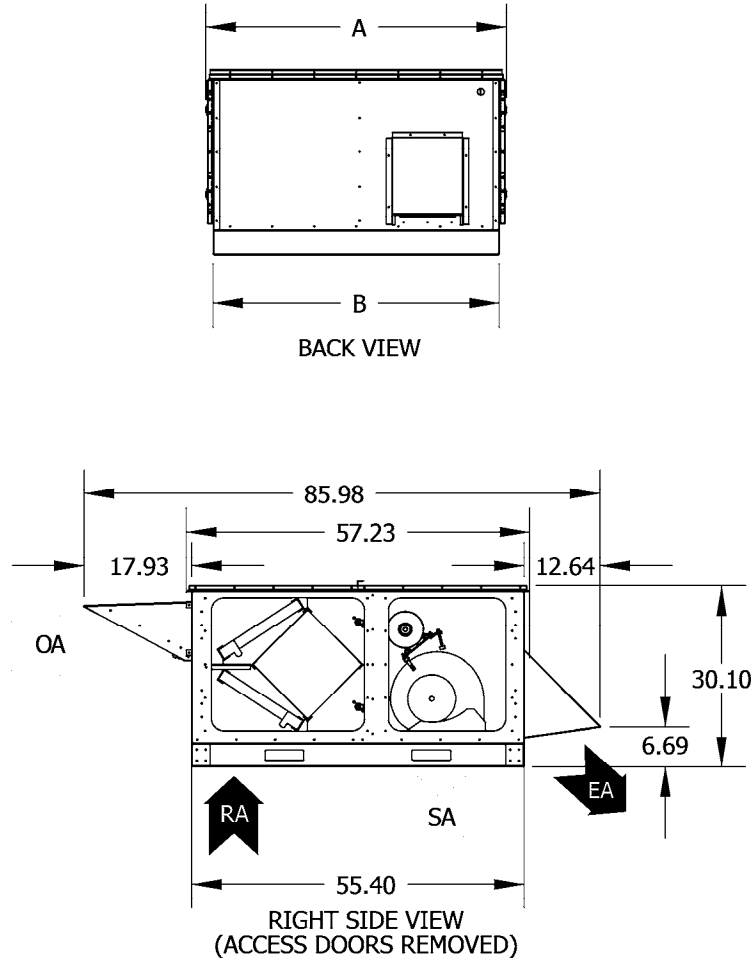
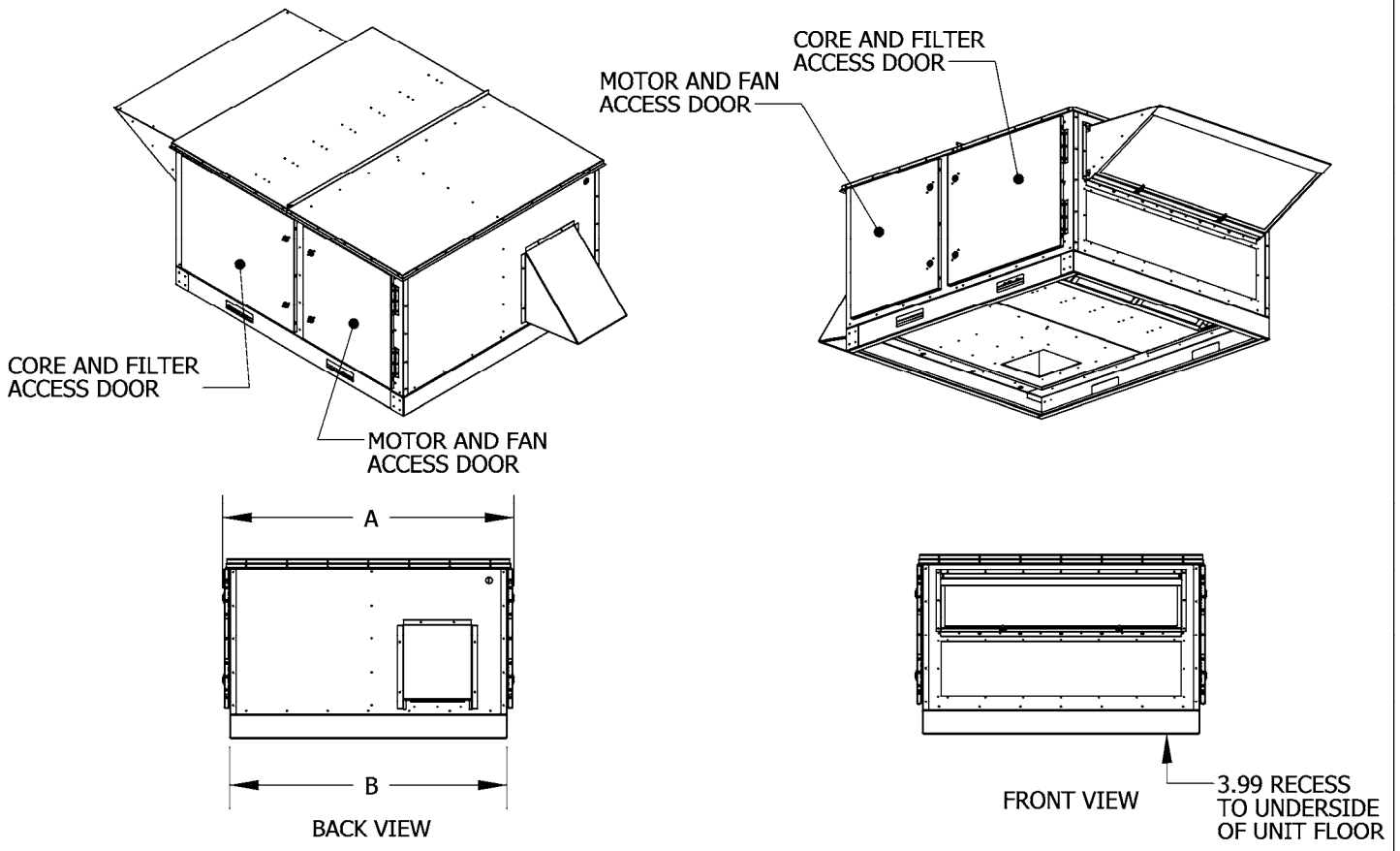

NOTES:
 SYSTEM IS INTENDED FOR OUTDOOR USE

OA - OUTSIDE AIR INTAKE
 SA - SUPPLY AIR EXIT
 RA - RETURN AIR INTAKE
 EA - EXHAUST AIR EXIT

FOLLOW ALL APPLICABLE CODES AND PROPER DESIGN PRACTICES TO ANCHOR SYSTEM TO ROOF AND CURB

F03R MODEL PICTURED

CORES	MODEL #	WEIGHT [LB]	A	B	C
2	F02R	460	34.36	31.96	29.08
3	F03R	545	50.11	47.71	44.83
4	F04R	645	65.86	63.46	60.58
5	F05R	730	81.61	79.21	76.33
6	F06R	815	97.36	94.96	92.08

Contact Information

For sales & application information, please contact us at:

Info@ConsERV.com

or

727-375-8484 x211

For installation & warranty information, please contact us at:

Tech@ConsERV.com

or

727-375-8484 x230

Please visit us at

www.ConsERV.com

to find out more about ConsERV™ technology
and to locate your local
ConsERV™ Manufacturer's Representative

ConsERV™ products provide...

- High latent heat transfer = high performance
- Improved indoor humidity and moisture control
- Peak demand and overall energy savings
- Excellent part load performance
- No rotating parts in the component - low maintenance
- No drain pans to worry about
- Safe downsizing of HVAC plants