

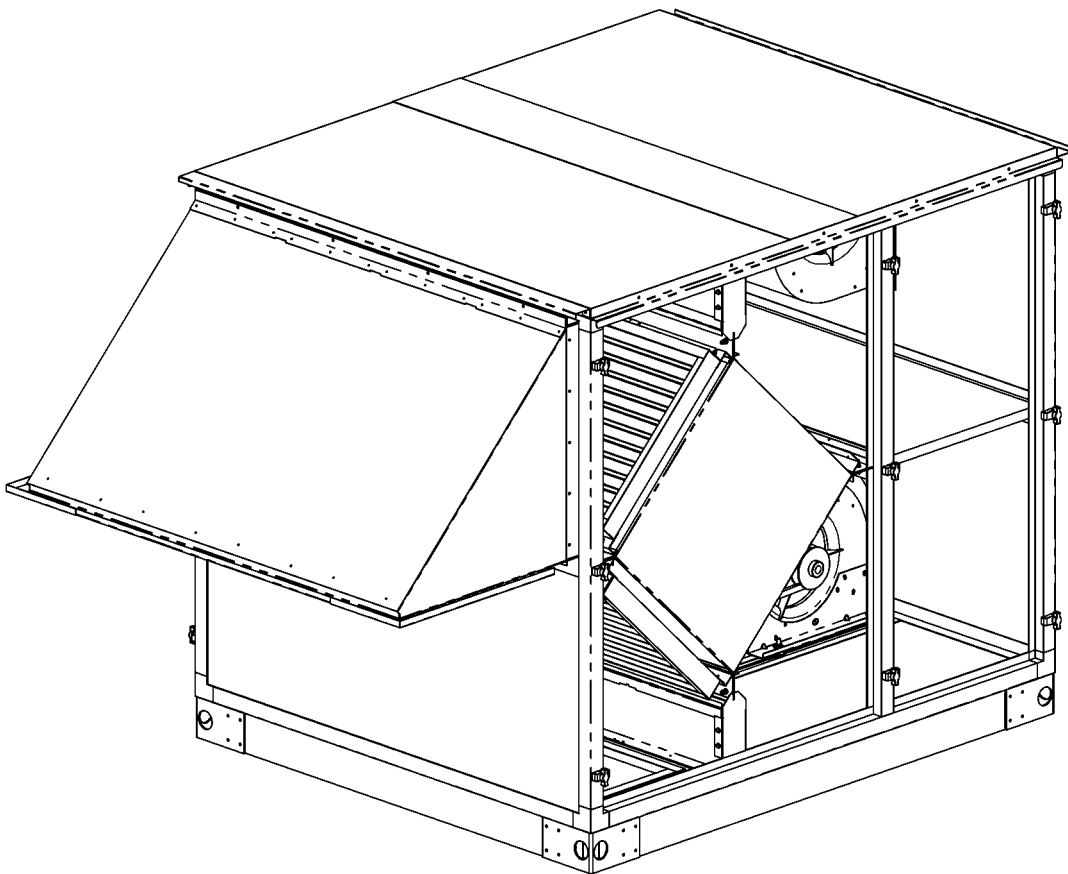

D Series Commercial Units

- Tailored solutions between 500 - 5500 CFM
- Indoor and rooftop versions available
- Internal fans available
- Lightweight, corrosion-resistant construction
- Wide variety of configurations



ver.5.3

Breakthrough technology...

Dais Analytic Corporation manufactures and sells the high performance ConsERV™ energy recovery ventilation system we introduced in 2002. Our patented polymer materials, grown out of space-age fuel cell research, are the key component of our revolutionary ConsERV™ air-to-air fixed-plate enthalpy exchangers. These unique materials provide the technology breakthrough that brings our customers unprecedented performance and energy savings in a reliable fixed-plate design.

An energy recovery ventilator (“ERV”) features a heat exchanger combined with ventilation to provide pre-conditioned air into a building. Pre-conditioning the air saves energy – and money – by reducing the load on your HVAC system. During the summer, outside air is cooled and dehumidified before it enters the building and your air conditioning system. During winter, the opposite occurs as the outside air is heated and humidified by the outgoing exhaust air. In most applications, both sensible heat transfer (temperature exchange) and latent heat transfer (moisture exchange) within the exchanger are desired. Until now, energy recovery wheels have been the principal means of providing this total energy transfer, since fixed plate products did not have the ability to transfer latent heat very well.

Enter Dais Analytic. Dais has developed the ConsERV™ energy exchanger, which transfers high levels of both sensible and latent heat and can reduce energy consumption and HVAC loads from fresh air ventilation by up to 80%. No rotating or moving parts in the exchanger mean less energy consumption by the ERV, lower maintenance costs, and peace of mind when downsizing HVAC equipment capacity.

Our ConsERV™ exchanger doesn't depend on open pores or fragile surface-mounted desiccants to transfer water from one air stream to the other. Instead, the polymer separating the air streams is organized at a nanometer level to create highly charged regions that draw water molecules into the material. There is no physical opening, so the polymer is hermetic and prevents crossover of air molecules. The water molecules move easily between charges along the polymer backbone, passing through the material from the side with higher vapor pressure to the side with lower vapor pressure.

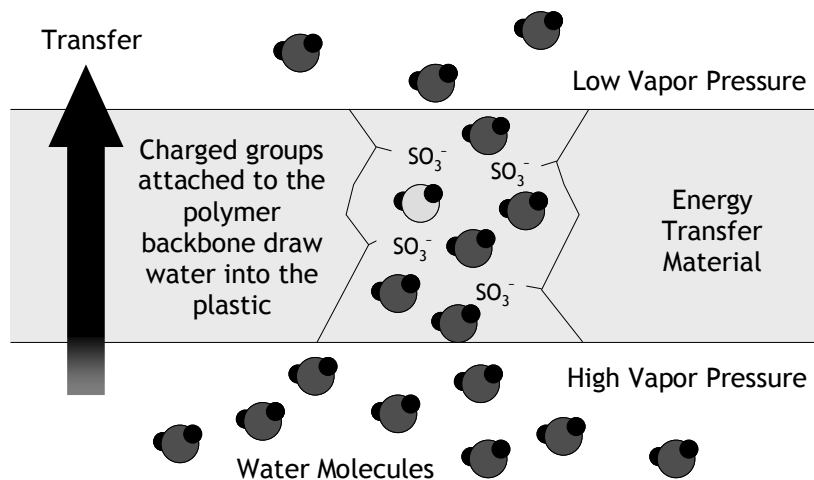

About ConsERV™...

Offering energy savings, rapid return on investment, and ease of use to consumers by pre-treating ventilation air.

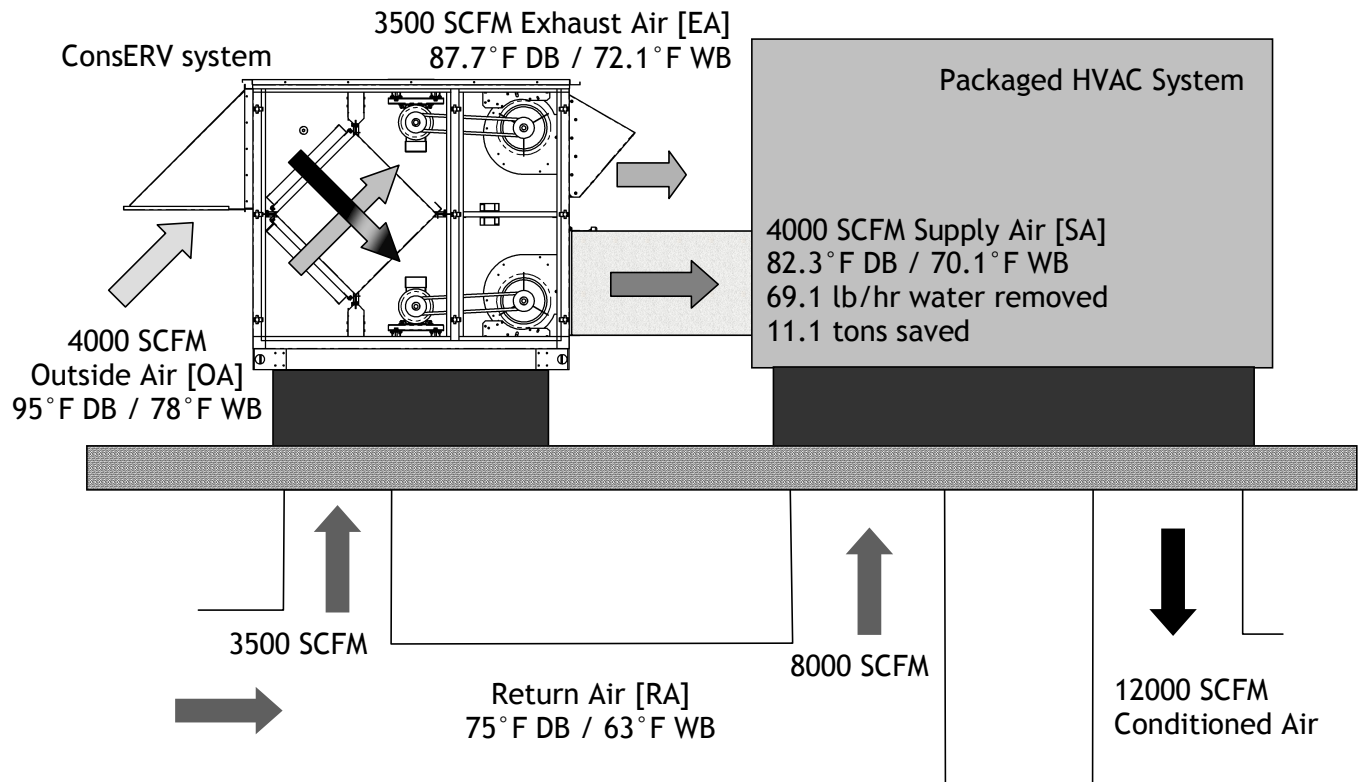

Example: D8R-FSE-xSHHVH system operating at AHRI Cooling conditions

Features and Benefits:

- Advanced materials = highest latent and total effectiveness of any fixed plate ERV
- No moving parts eliminates the most costly maintenance
- Savings of up to 30% on installed HVAC capital costs and up to 50% on operating costs
- Failsafe operation - transfers energy as long as there is airflow
- Reliability allows safer downsizing of attached HVAC equipment.
- Zero air stream leakage - core does not allow cross contamination
- No defrost needed in most climate zones
- Equally effective in both summer and winter = year-round savings
- Water stays in vapor phase = no liquid water
- Light, corrosion-resistant aluminum cabinets offer double wall construction, 5.7 R-value
- Steel cabinets offer single or double wall options
- Industry standard electrical and monitoring options
- Easy installation with flexible air flow configurations and a smaller installed footprint

Certifications and Awards:

- UL 900 Recognized, UL 1812 Ducted ERV
- AHRI 1060 certified performance
- 2006 AHR Ventilation Innovation Award winner

D Series Ordering System

D Series units have a number of different specifications that must be known before manufacturing begins. These are detailed according to an alphanumeric model number with the following format:

D _ - _ - - - - -

Model Number Key		D	-	-	-	-	-	-	-	-	-	-	-
D = D series	Overall system type												
2 thru 9	# of C500S cores in system												
i = Indoor R = Rooftop	Installation location												
F = Fans N = No fans	Internal blowers												
S = Standard L = Low-profile	Height of system												
S = Standard E = Extended	Length of duct openings												
N = None A = 115V / 1 ϕ B = 208V / 1 ϕ C = 208V / 3 ϕ D = 230V / 1 ϕ E = 460V / 3 ϕ F = other	Electrical service (All are 60 hz)												
S = Side quadrants T = Top quadrants B = Bottom quadrants	Location of intake filters												
H = Horizontal V = Vertical	Stream 1 entrance direction												
H = Horizontal V = Vertical S = Side	Stream 1 exit direction												
H = Horizontal V = Vertical	Stream 2 entrance direction												
H = Horizontal V = Vertical S = Side	Stream 2 exit direction												

Example: D5i-FSE-CSHHH

5 ConsERV™ C500S cores in a standard height indoor cabinet with extended duct openings. Internal fans are included, operating on 208V/3 ϕ power, the filters are located in the side quadrants of the unit, and all of the duct openings are oriented horizontally.

D Series Options

Electrical Disconnects

Factory installed electrical disconnects are available for all D Series ERV units. Disconnects are sized to meet the power requirements of the system and are available either fused or non-fused. The rotary disconnect knob is externally mounted for remote operation of the switch with the access panels in place.

Occupancy Timers

For those applications where the D Series ERV is to be operated based on occupancy or on a time and day basis, a programmable control timer is available. The digital control timer is internally mounted and can be programmed with a 7-day cycle and up to 10 on/off cycles per day.

Anchor Straps →

Anchor straps constructed of 14 gauge galvanized steel and pre-drilled for 1/4" mounting hardware are available to secure rooftop units to their curbs.

Variable Frequency Drives (VFD)

The D Series ERV units allow a VFD to be added to the unit to control the speed of the either or both motor/fan assemblies. The drive unit is mounted internally and the keypad is available either internally mounted or external mounted.

Vertical Electrical Connections

For those applications where the project does not want electrical wiring external to the unit, the D Series ERV units have an option to have the wiring provided through the floor of the box and then into the facility through the curb.

Insect Screens

D Series ERV units are available with a high density aluminum mesh screen mounted at the entrance to the supply hood to prevent most insects from entering the unit. The screens also provide increased protection against rain ingestion in the highest-intensity storms.

“Mirror Image” Duct Openings

Units with standard ducts and without internal fans can be built with the usual arrangement of openings and panels reversed to create a “mirror image” design to better fit space constraints. See page 15 for more details.

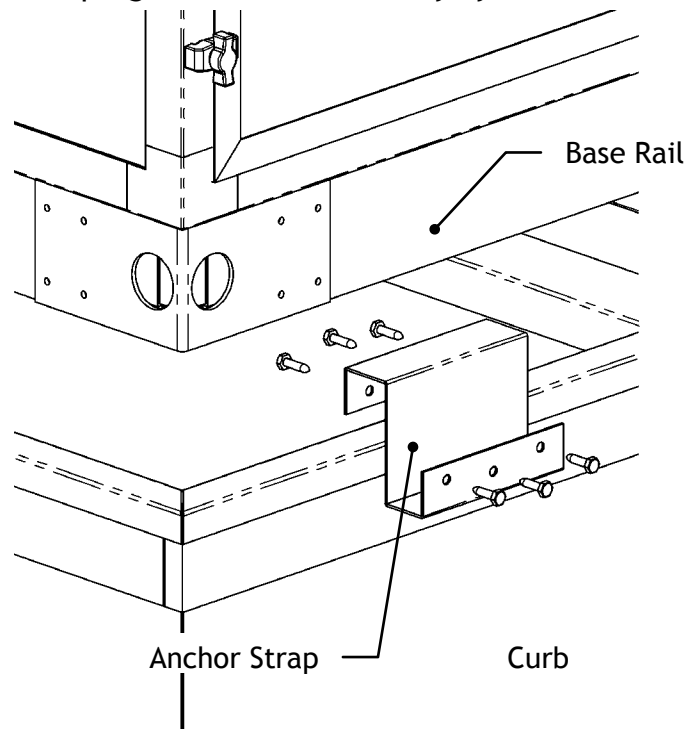

D Series “No Fan” Flow Configurations

The aluminum space frame construction of our D series systems allows a flexible manufacturing strategy. The location of frame members and panels can create up to 32 different flow configurations, allowing engineers to place the system in almost any location in a mechanical room. These flow configurations are independent of the height or opening size of the cabinet, so they apply equally to the i-NLS-Nxxxxx models (shown below), i-NSS-Nxxxxx models, and i-NSE-Nxxxxx models. Specify the desired configuration by using the last five digits of the model number to locate the filters either on the left or top and set the orientation of each of the inlets and outlets. For consistency, Stream 1 always originates in the upper left hand corner as you look at the right side view of the system.

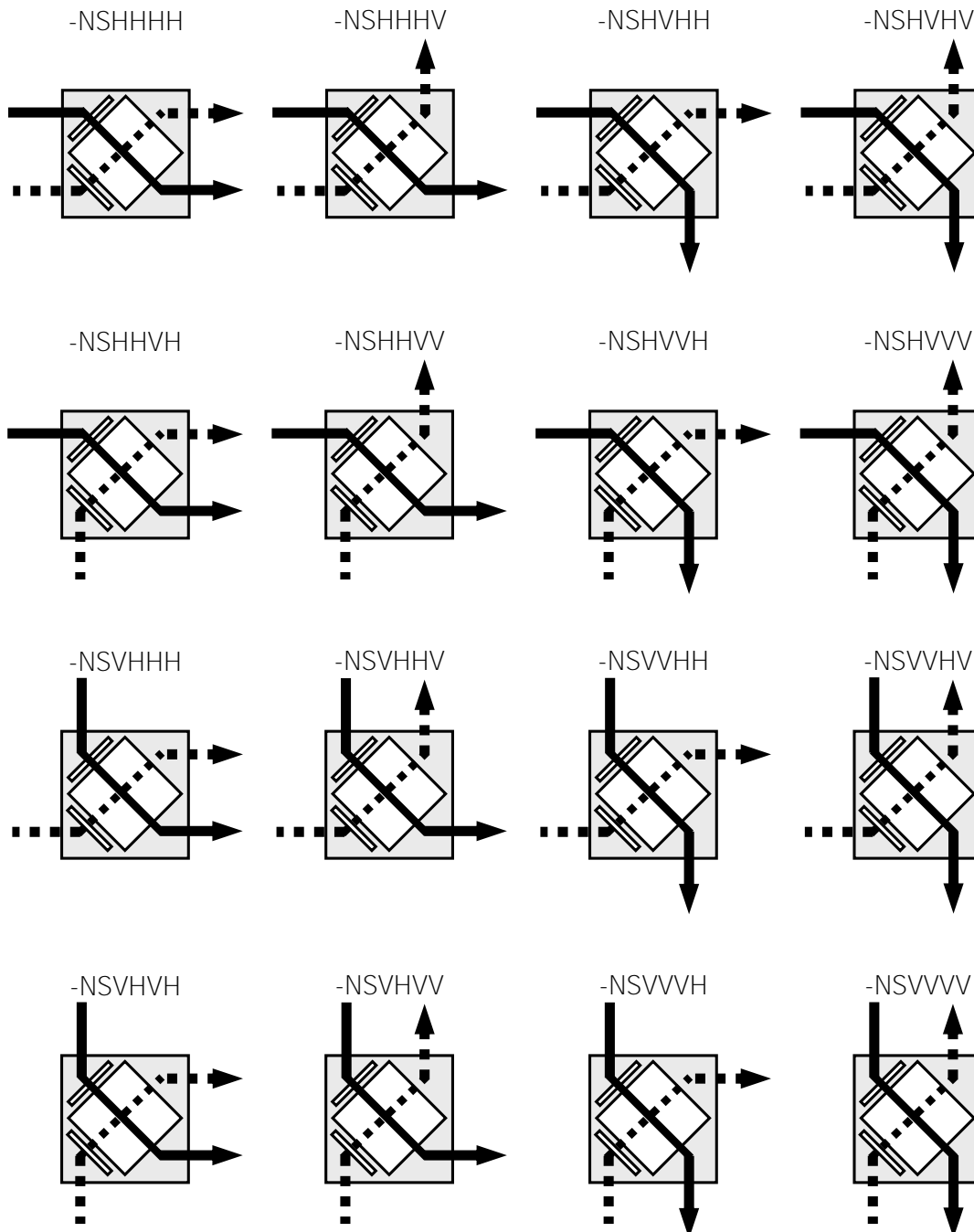

D Series “No Fan” Flow Configurations

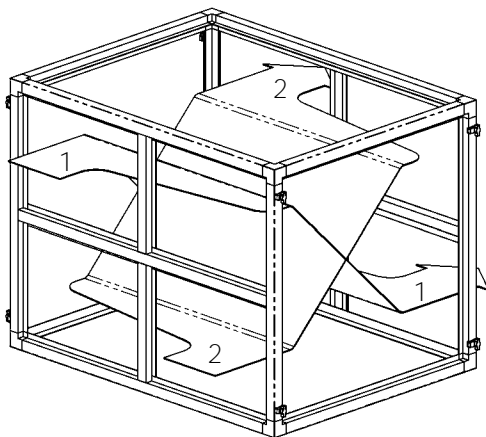
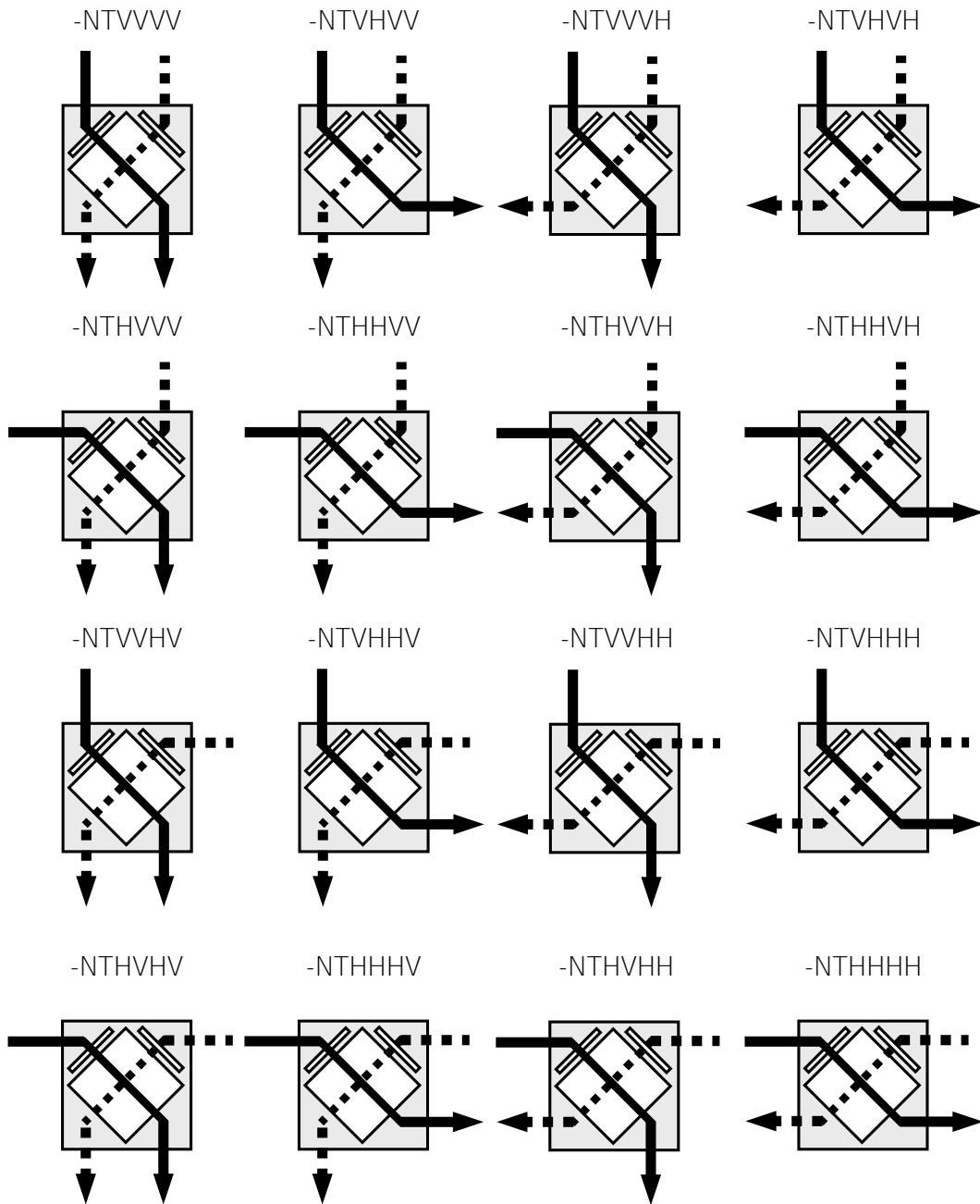

“Standard” Duct Opening Systems

“Standard” duct openings only extend half the length of a system, meaning the air has to travel lengthwise to spread evenly across the cores. Air streams travel in a “Z” pattern through the system, as shown in the diagram to the left. Stream 1 enters through the opening on the top left and exits through the opening on the bottom right. Stream 2 follows an opposite flow geometry.

D4i-NLS-NSHHHH (default) shown
(panels and internal components removed for clarity)

D Series “No Fan” Flow Configurations

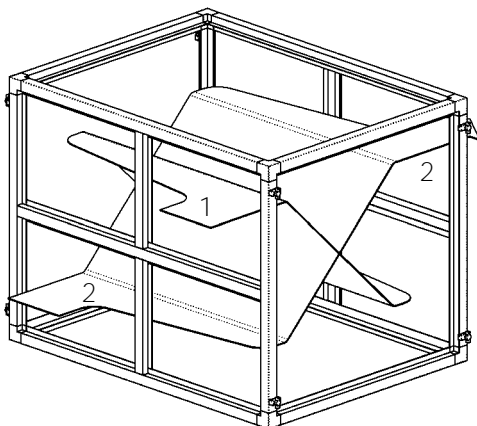
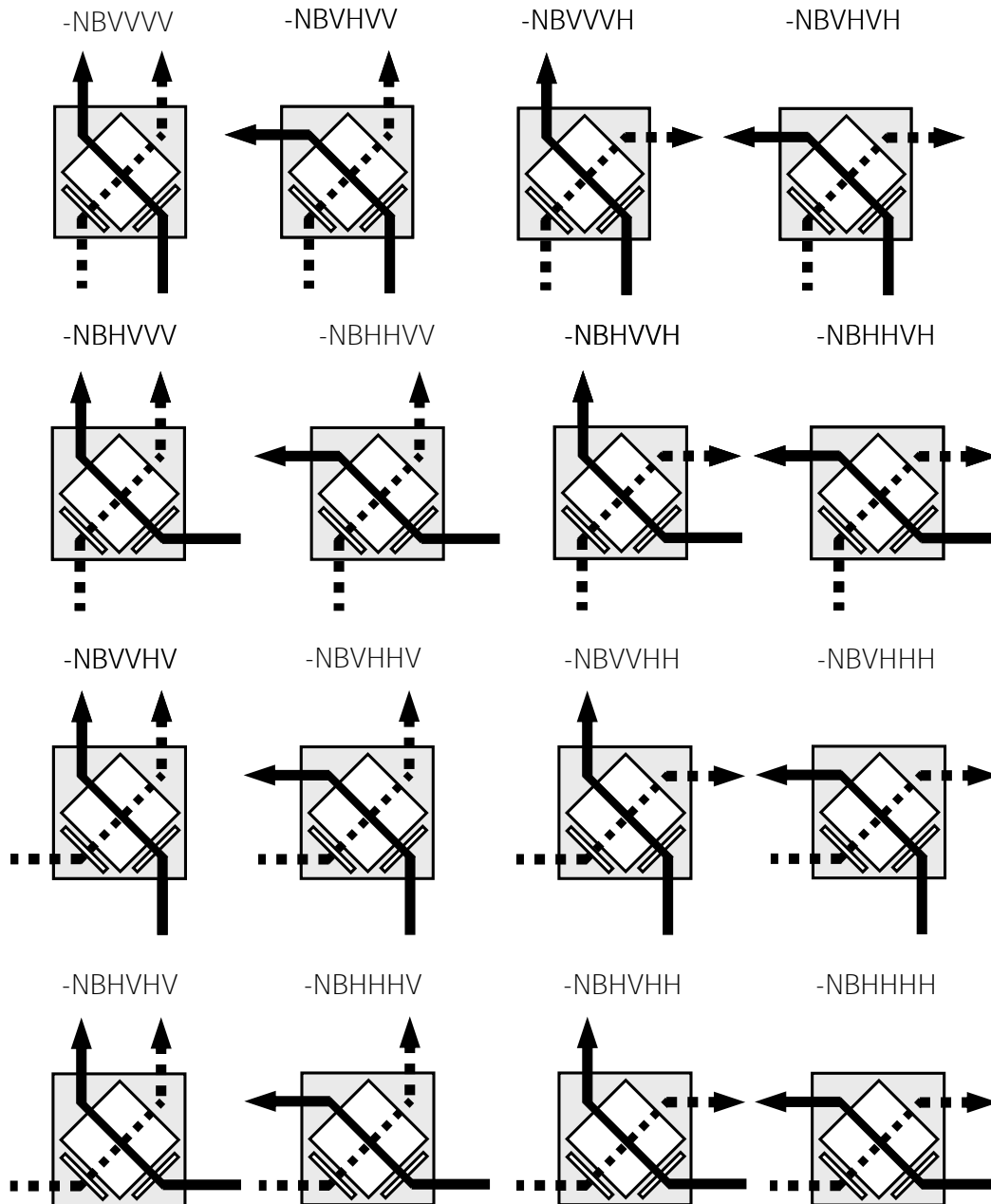

Mirror Image Duct Openings

The default arrangement of duct openings is not always the most appropriate for every opportunity. A “mirror image” is available, where the openings to the unit are swapped with the solid panels. In the instance shown here, the air enters the unit in the top right and bottom left quadrants instead of the top left and bottom right.

D4i-NLS-NSHHHH (mirror) shown
(panels and internal components removed for clarity)

D Series Electrical Information

For systems with internal fans, determine the motor horsepower based on the flow and external static pressure tables on the chosen model's catalog pages and use it to specify the Full Load Amp (FLA) rating from the tables below. The procedures to the right calculate the Minimum Circuit Ampacity (MCA) and the Maximum Overcurrent Protection (MOP).

Single Phase	Motor Full Load Amp (FLA) Rating			
	115V	208V	230V	460V
1/2 hp	9.8	5.4	4.9	N/A
3/4 hp	13.8	7.6	6.9	N/A
1 hp	16	8.8	8	N/A
1.5 hp	20	11	10	N/A
2 hp	24	13.2	12	N/A
3 hp	N/A	18.7	17	N/A
Three Phase	Motor Full Load Amp (FLA) Rating			
	115V	208V	230V	460V
1/2 hp	N/A	2.4	2.2	1.1
3/4 hp	N/A	3.5	3.2	1.6
1 hp	N/A	4.6	4.2	2.1
1.5 hp	N/A	6.6	6	3
2 hp	N/A	7.5	6.8	3.4
3 hp	N/A	10.6	9.6	4.8
5 hp	N/A	16.7	15.2	7.6
7.5 hp	N/A	24.4	22	11
Control FLA	115V	208V	230V	460V
FLA _{control}	0.43	0.24	0.22	0.11

System Full Load Amp Rating (FLA)

$$FLA = FLA_{\text{motor1}} + FLA_{\text{motor2}} + FLA_{\text{control}}$$

Minimum Circuit Ampacity (MCA)

$$MCA = 1.25 FLA$$

Maximum Overcurrent Protection (MOP)

1. Determine max and min motor FLA and calculate

$$MOP = 2.25 FLA_{\text{max}} + FLA_{\text{min}} + FLA_{\text{control}}$$

2. Round MOP down to the nearest multiple of 5

$$MOP = \text{Floor} (MOP , 5)$$

3. MOP must be \geq MCA rounded up to a multiple of 5

$$MOP = \text{Max} (MOP , \text{Ceiling} (MCA , 5))$$

4. MOP must be at least 15 amps (the minimum fuse)

$$MOP = \text{Max} (MOP , 15)$$

MOP should always be a multiple of 5 \geq 15

Electrical and Control Information

All systems with internal fans are provided with a control system that includes:

- 24 VAC control transformer with fused output
- 2 contactors
- Interlock switches that shut down the fans if an access panel is removed

The motor contactors are factory wired for independent control of the fans, meaning they have two external contact points and a common 24 VAC neutral point. Simultaneous fan operation can be chosen by field-wiring both contact points to the same external control relay.

Optional fused and non-fused disconnect switches are available. These and other electrical options modify the basic schematics shown to the right, and schematics detailing these options are available on request.

D Series Electrical Information

Single Phase Electrical Schematic

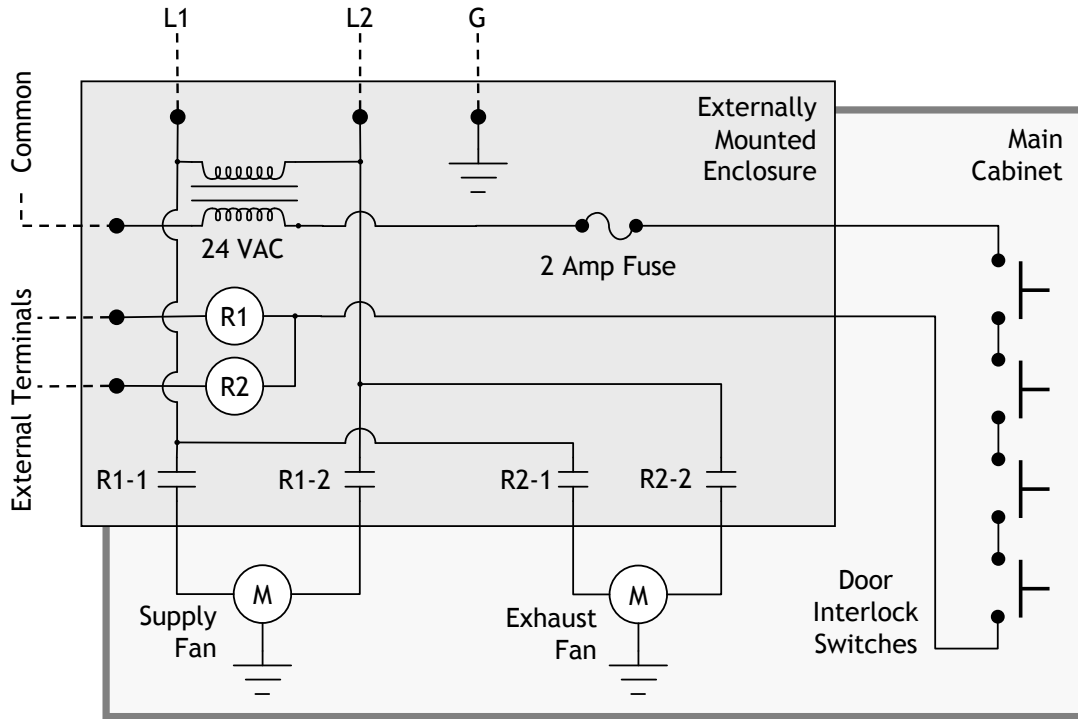

Three Phase Electrical Schematic

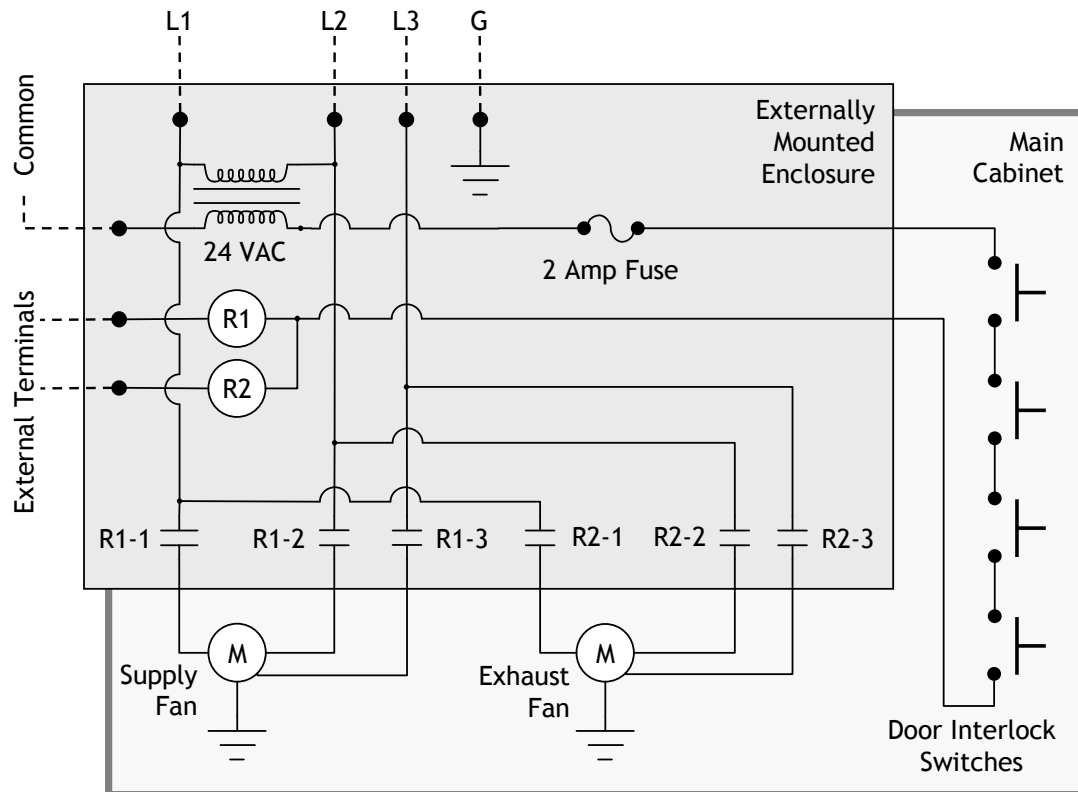

----- Dashed lines indicate wiring supplied by others.

D Series Specifications and Construction

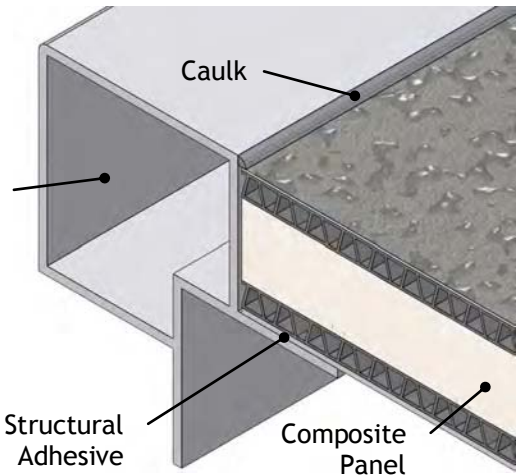
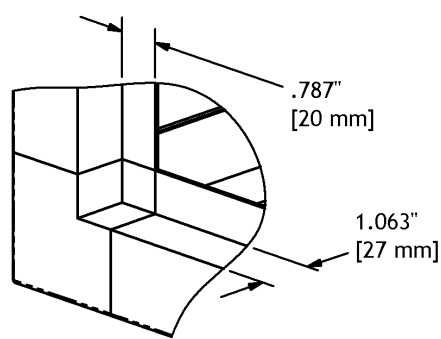
<p>Airflow Range: 500–5,400 CFM, standard design, up to 20,000 cfm custom design</p>
<p>ERV Cores: Exclusive Dais-Analytic Corp. ConsERV™ Model C500S (2 - 9 cores per unit) AHRI 1060 Certified, UL 900 Recognized, UL 1812 Duct Mounted ERV</p>
<p>Fans: Units available with or without fresh air and exhaust air fans</p>
<p>Electrical: Units with factory installed fans include single point electrical connection/relay panel</p>
<p>Cabinet Housing: Constructed of cast and extruded aluminum framing components with 1” thick composite panels. Structural-strength acrylic adhesive and silicone caulk beads create a dual sealing mechanism.</p> <p>Aluminum Extrusion</p> <p>Structural Adhesive</p> <p>Composite Panel</p> <p>Caulk</p> <p>Panels consist of a closed-cell insulating foam sandwiched between corrugated plastic stabilizers and pre-finished aluminum sheets. R-value is 5.7 hr-ft² °F/Btu and panels are wind load rated to 167 miles/hour (ASTM E330) and Class A fire rated (ASTM E84).</p> 
<p>Filters: 2” thick MERV 8 pleated filters on entrance faces of ConsERV™ cores included with unit</p>
<p>Duct Mounting: Typical entrance and exit openings are a recess in the aluminum frame, dimensioned as shown to the right. Exit flanges around internal fans are constructed from .040” thick 5052 sheet aluminum and project 2.00” from the unit, with lengths and widths shown on individual drawings.</p> 
<p>Roof Curbs: Available, specify when ordering</p>
<p>Air Temperature Operating Range: -10* to 140 °F</p>
<p>Differential Pressure: Unit capable of withstanding 2” H₂O differential pressure between airstreams during normal operation. Unit can withstand 4” H₂O maximum differential pressure between airstreams and return to normal operation without damage.</p>
<p>Maintenance: Filter changes according to recommendations of filter manufacturer Vacuum both entrance faces of the ConsERV™ cores twice per year (no washing necessary) Access panels allow for visual inspection and maintenance</p>
<p>Limited Parts Warranty: 10 years for ConsERV™ core 2 years for unit housing and fans Additional terms and conditions apply; refer to full Warranty document for details</p>

* System components are designed to withstand -30 °F. Please consult with your ConsERV™ sales representative for low temperature operational details below -10 °F.

D Series Roof Curbs

NOTES:

STANDARD 14" TALL FLAT-ROOF CURB
 18 GA. GALVANIZED STEEL CONSTRUCTION
 KNOCKDOWN CONSTRUCTION
 1" X 4" WOOD NAILERS TO ATTACH ROOFING MATERIAL
 DUCT DIVIDERS ARE FIELD INSTALLED TO MATCH DUCT WIDTH
 ANCHOR STRAPS ARE AVAILABLE TO FASTEN CONSERV UNIT

Model Number	# Cores	A
D2R-STD-CURB	2	23.00
D3R-STD-CURB	3	35.25
D4R-STD-CURB	4	47.63
D5R-STD-CURB	5	60.00
D6R-STD-CURB	6	72.38
D7R-STD-CURB	7	84.63
D8R-STD-CURB	8	97.00
D9R-STD-CURB	9	109.38

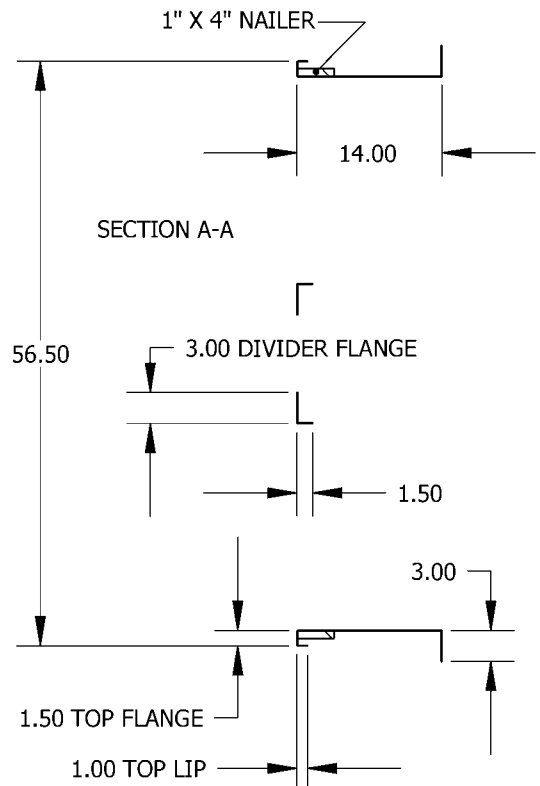
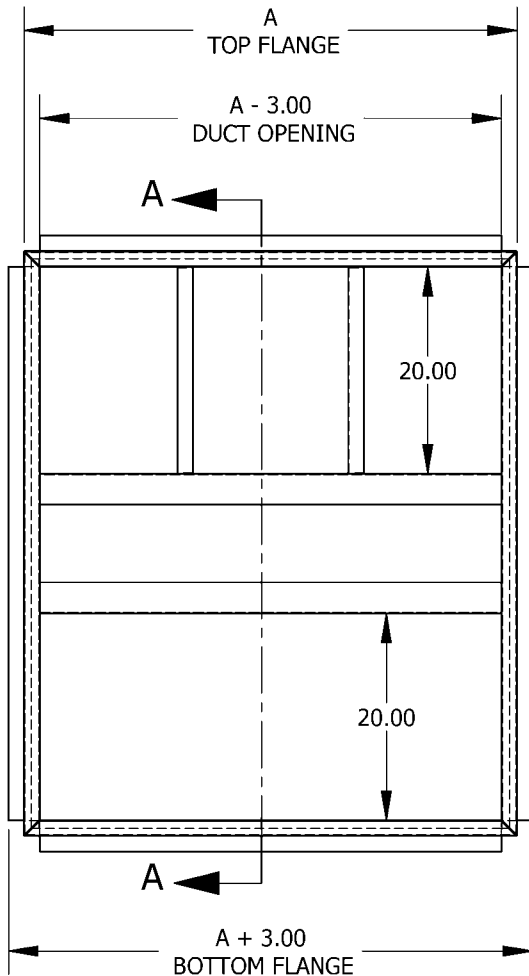
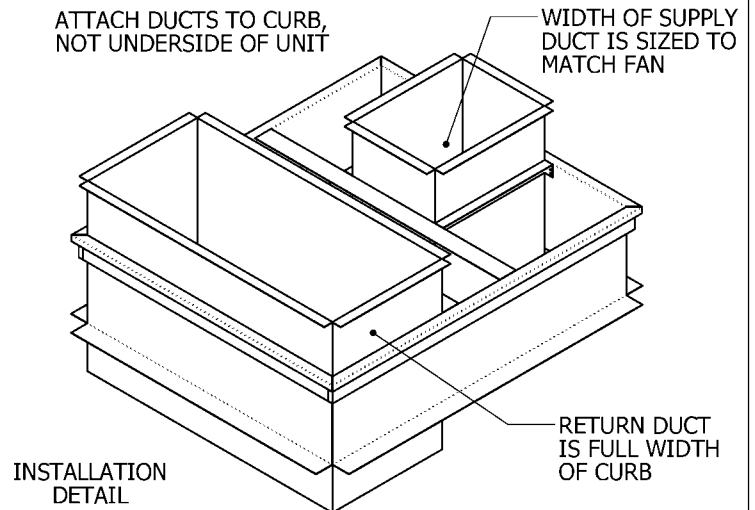
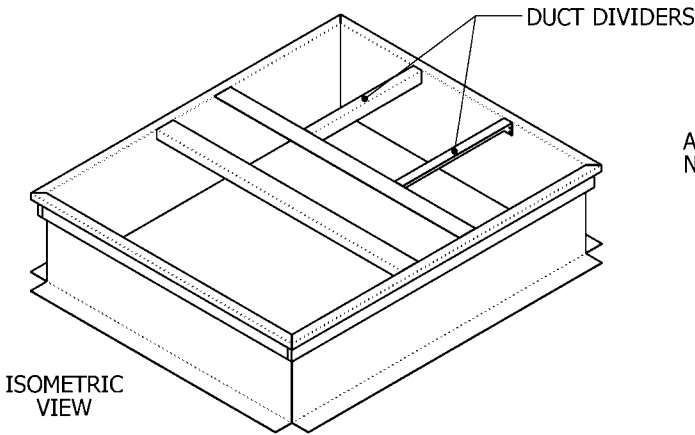

D Series → Model i-NSS-Nxxxxx

A standard height indoor system that offers a flexible duct connection pattern while minimizing the static pressure drop through the system. Construction is aluminum space frame with corrosion-resistant hardware and double-walled coated aluminum panels, whose closed-cell foam insulation results in a 5.7 R-value.

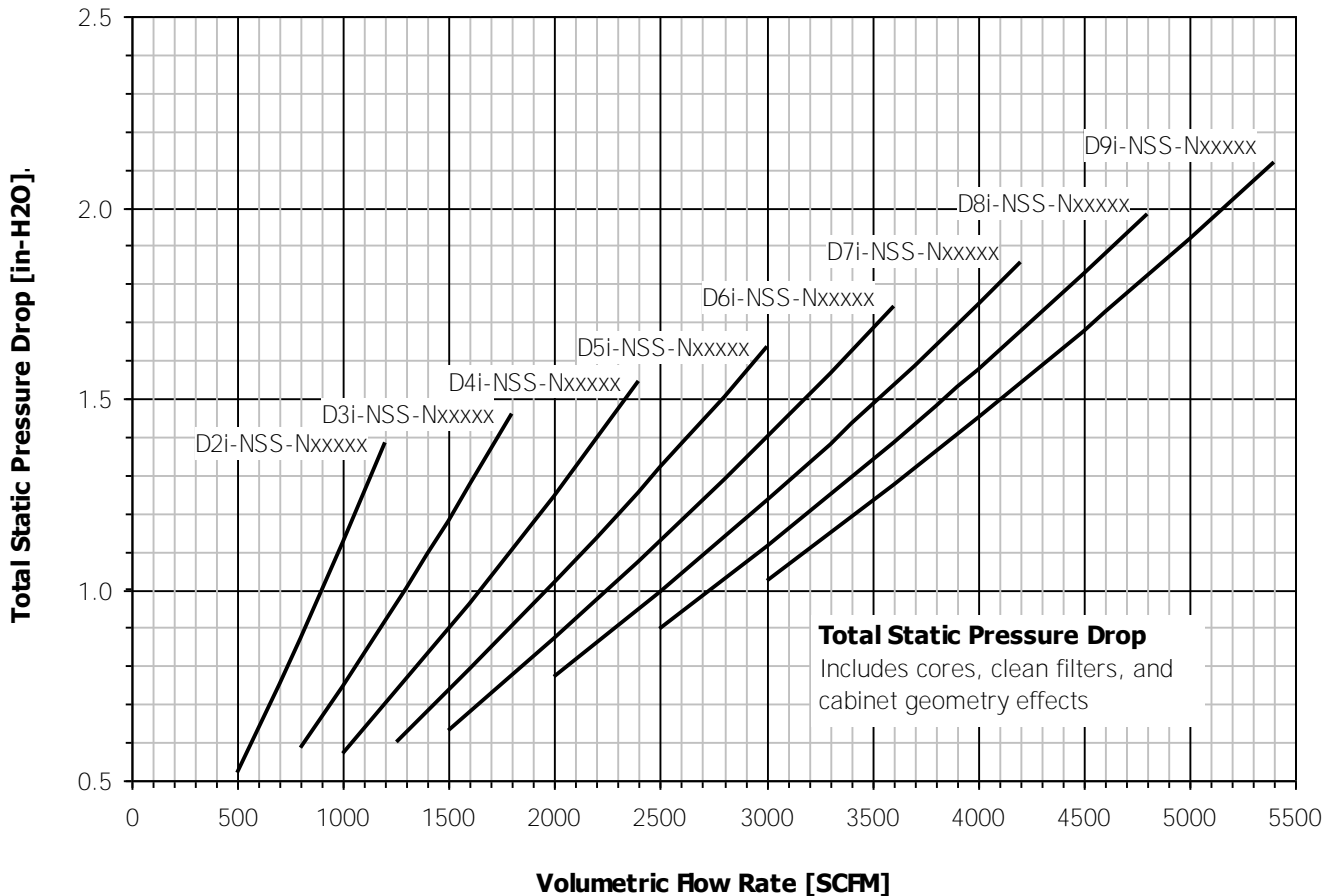
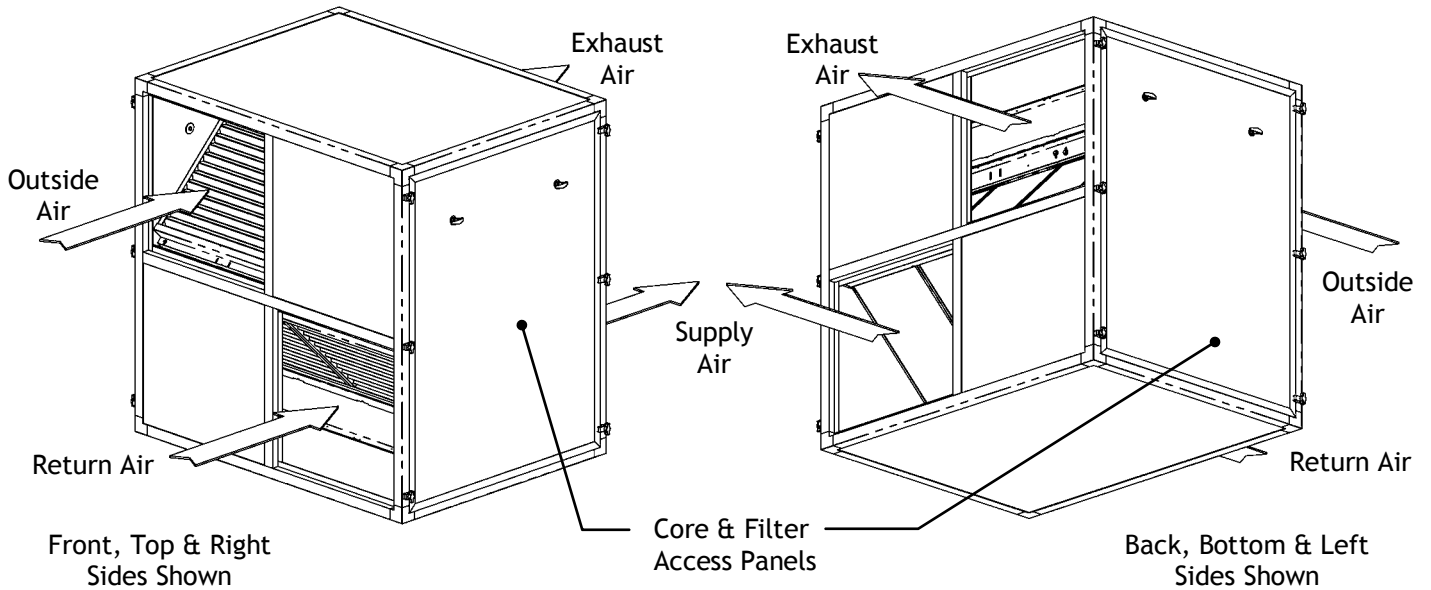

# CORES	MODEL #	A	B	C	WEIGHT [LB]
2	D2i - NSS	29.18	26.72	11	208
3	D3i - NSS	41.52	39.06	17.17	276
4	D4i - NSS	53.87	51.41	23.34	344
5	D5i - NSS	66.21	63.75	29.51	412
6	D6i - NSS	78.55	76.09	35.68	480
7	D7i - NSS	90.9	88.44	41.86	548
8	D8i - NSS	103.24	100.78	48.03	616
9	D9i - NSS	115.59	113.13	54.2	684

NOTES:

SYSTEM IS INTENDED FOR INDOOR USE

D4i-NSS-NSHHHH MODEL PICTURED

32 FLOW CONFIGURATIONS AVAILABLE FOR PRE-ORDER
(SEE ORDER INFORMATION SHEETS FOR DETAILS)

DIFFERENT FLOW CONFIGURATIONS CAN CHANGE
PLACEMENT OF OPENINGS AND STRUCTURAL DETAILS,
BUT DIMENSIONS ARE VALID THROUGHOUT MODEL LINE

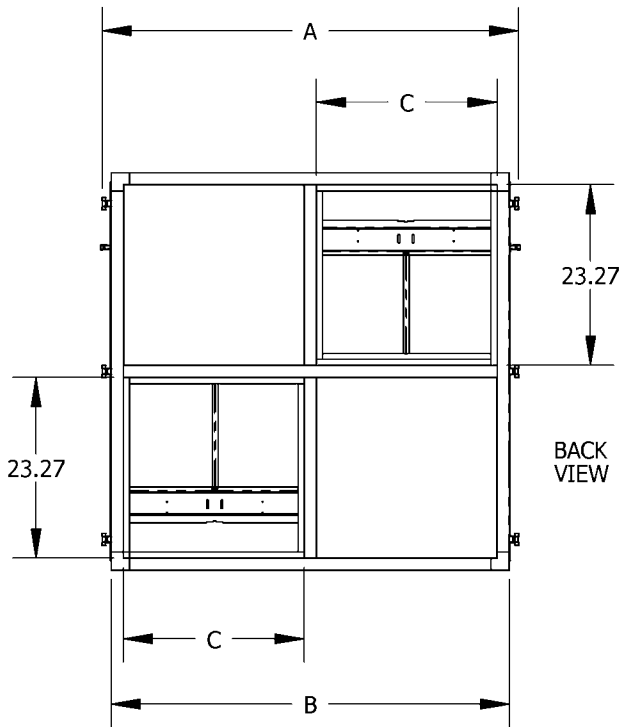

TOP VIEW
(RECOMMENDED
SERVICE AREA
SHOWN)

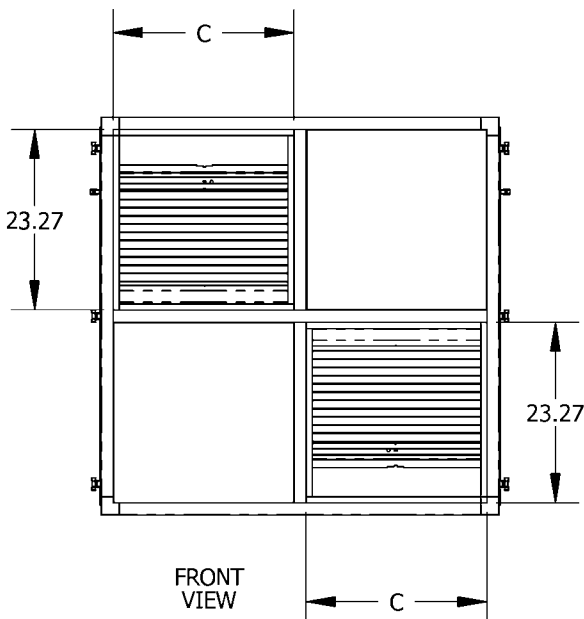
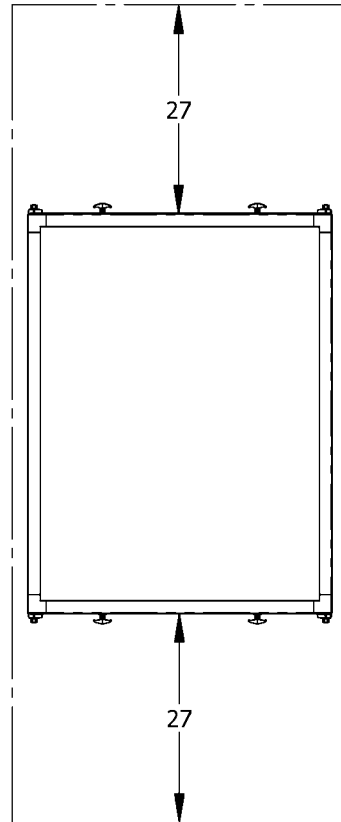

RIGHT SIDE VIEW
(ACCESS PANELS
REMOVED)

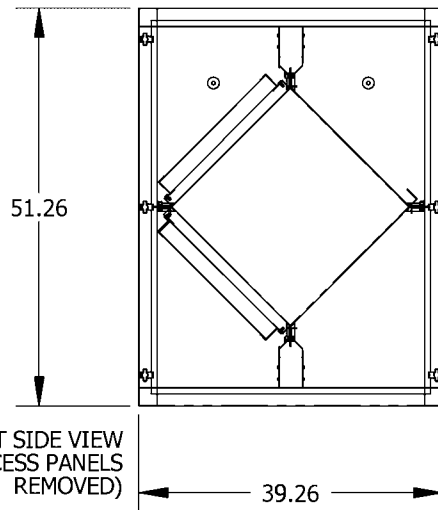

D Series → Model i-NLS-Nxxxxx

A low-profile indoor system that offers a flexible duct connection pattern in the smallest possible footprint. Construction is aluminum space frame with corrosion-resistant hardware and double-walled coated aluminum panels, whose closed-cell foam insulation results in a 5.7 R-value.

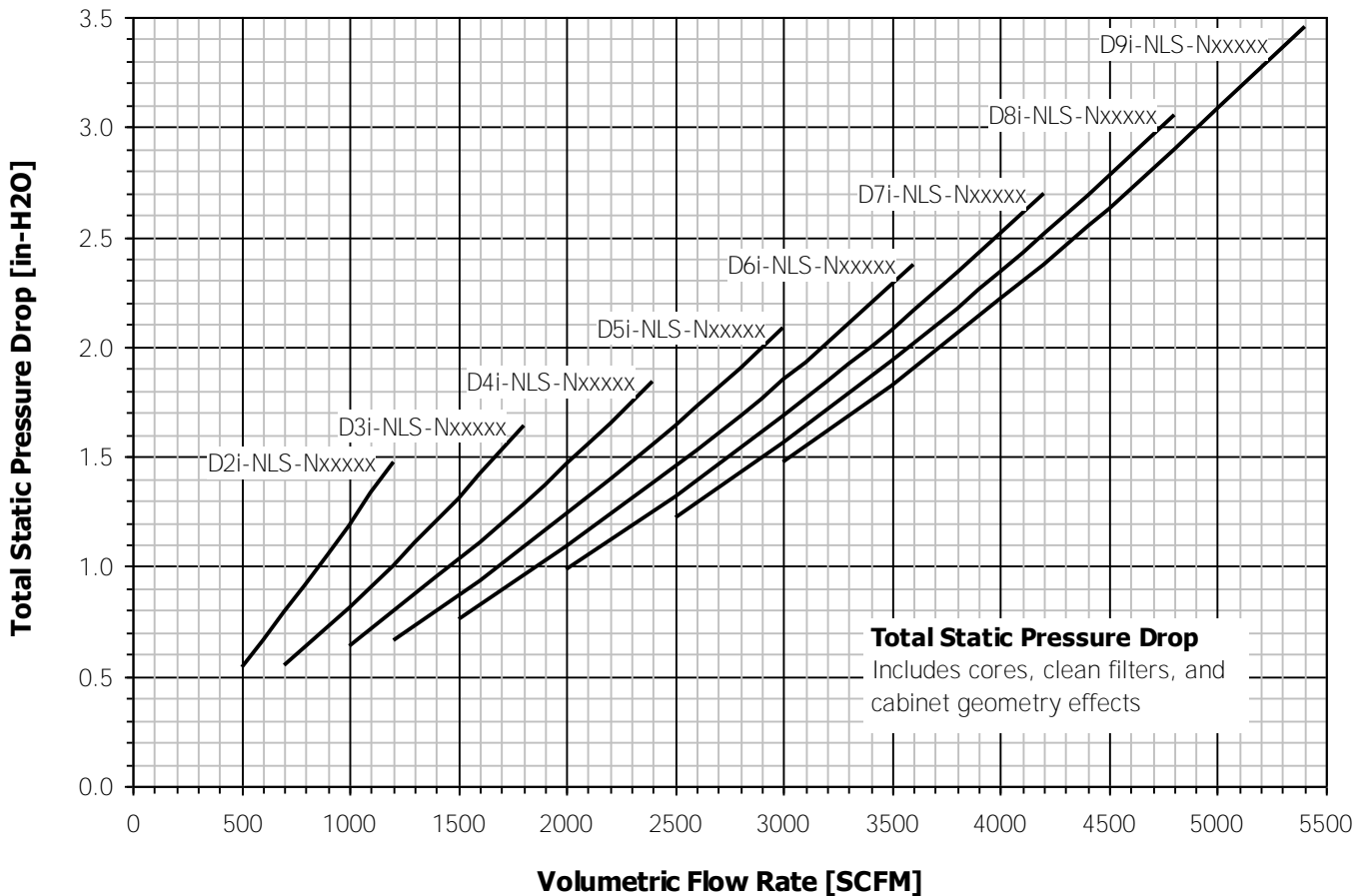
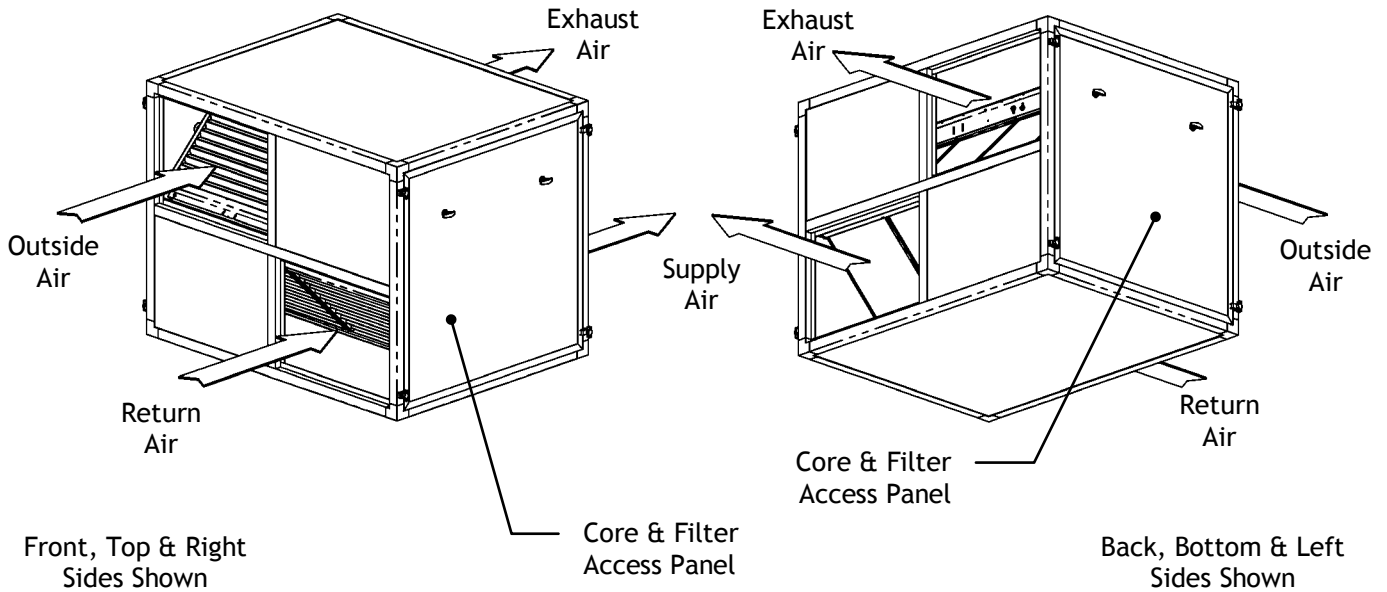

# CORES	MODEL #	A	B	C	WEIGHT [LB]
2	D2i - NLS	29.18	26.72	11	181
3	D3i - NLS	41.52	39.06	17.17	242
4	D4i - NLS	53.87	51.41	23.34	303
5	D5i - NLS	66.21	63.75	29.51	364
6	D6i - NLS	78.55	76.09	35.68	425
7	D7i - NLS	90.9	88.44	41.86	486
8	D8i - NLS	103.24	100.78	48.03	547
9	D9i - NLS	115.59	113.13	54.2	608

NOTES:

SYSTEM IS INTENDED FOR INDOOR USE

D4i-NLS-NSHHHH MODEL PICTURED

32 FLOW CONFIGURATIONS AVAILABLE FOR PRE-ORDER
(SEE ORDER INFORMATION SHEETS FOR DETAILS)

DIFFERENT FLOW CONFIGURATIONS CAN CHANGE
PLACEMENT OF OPENINGS AND STRUCTURAL DETAILS,
BUT DIMENSIONS ARE VALID THROUGHOUT MODEL LINE

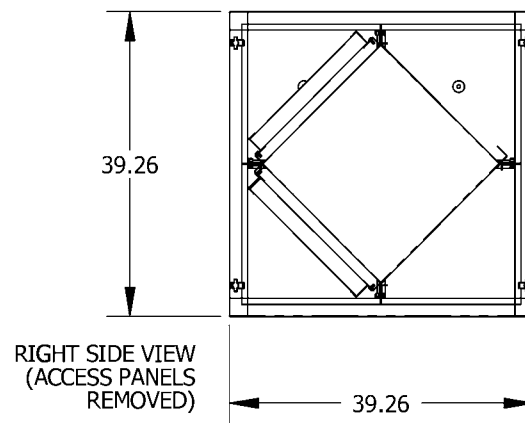
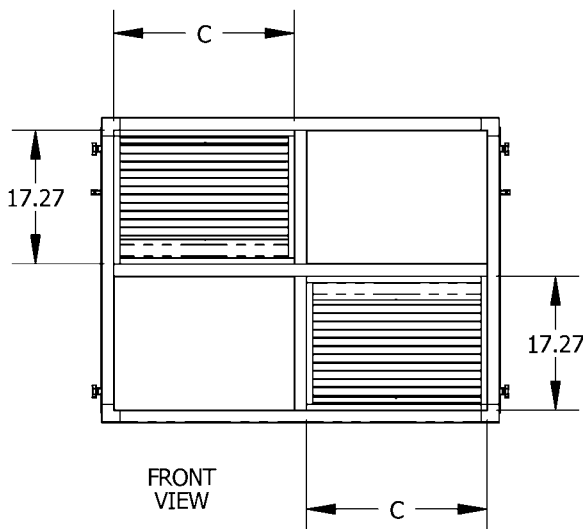
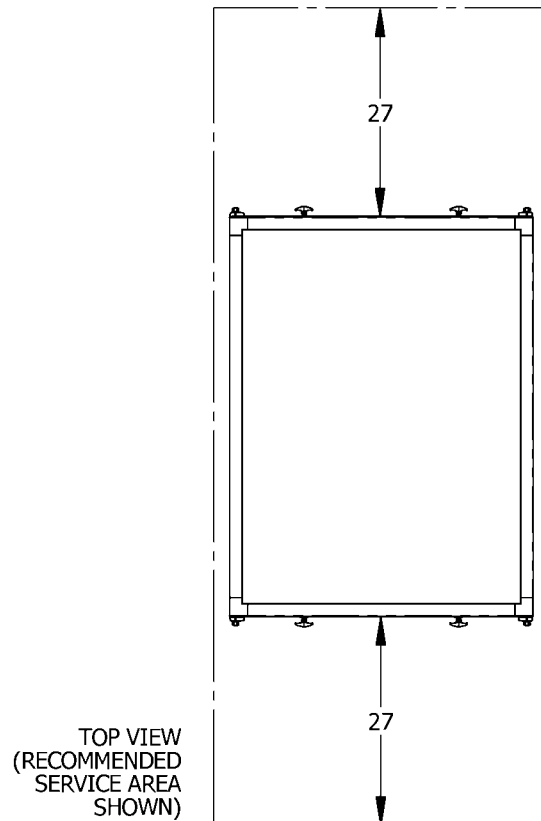
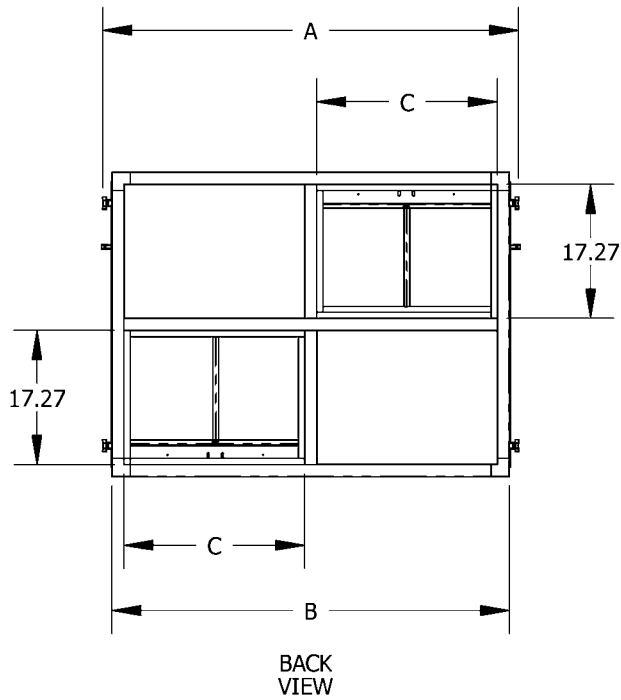

D Series → Model i-NLE-Nxxxxx

A low-profile indoor system with extended duct connection openings in the smallest possible footprint. Construction is aluminum space frame with corrosion-resistant hardware and double-walled coated aluminum panels, whose closed-cell foam insulation results in a 5.7 R-value.

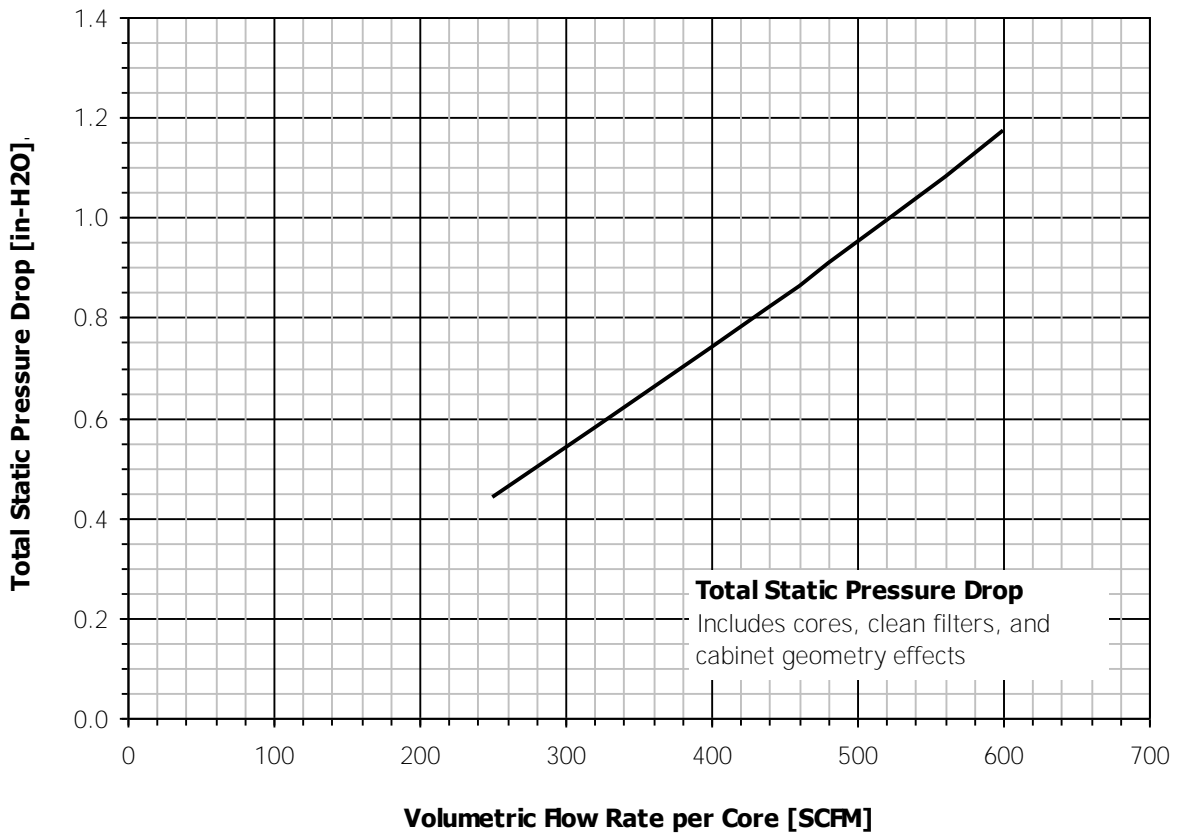
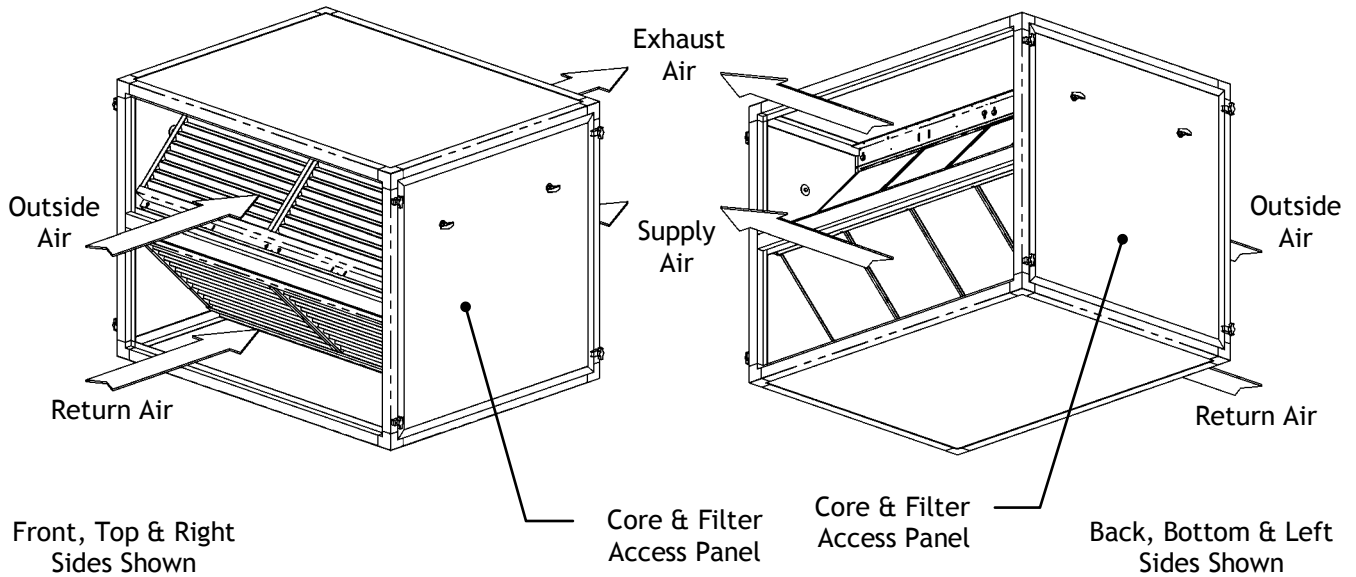

# CORES	MODEL #	A	B	C	WEIGHT [LB]
2	D2i - NLE	29.18	26.72	23.57	171
3	D3i - NLE	41.52	39.06	35.91	227
4	D4i - NLE	53.87	51.41	48.26	283
5	D5i - NLE	66.21	63.75	60.6	339
6	D6i - NLE	78.55	76.09	72.94	395
7	D7i - NLE	90.9	88.44	85.29	451
8	D8i - NLE	103.24	100.78	97.63	507
9	D9i - NLE	115.59	113.13	109.98	563

NOTES:

SYSTEM IS INTENDED FOR INDOOR USE

D4i-NLE-NSHHHH MODEL PICTURED

32 FLOW CONFIGURATIONS AVAILABLE FOR PRE-ORDER
(SEE ORDER INFORMATION SHEETS FOR DETAILS)

DIFFERENT FLOW CONFIGURATIONS CAN CHANGE
PLACEMENT OF OPENINGS AND STRUCTURAL DETAILS,
BUT DIMENSIONS ARE VALID THROUGHOUT MODEL LINE

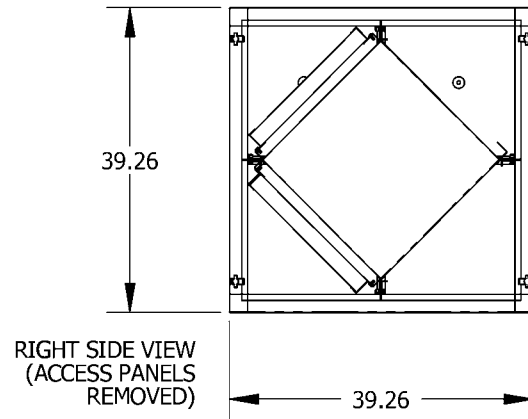
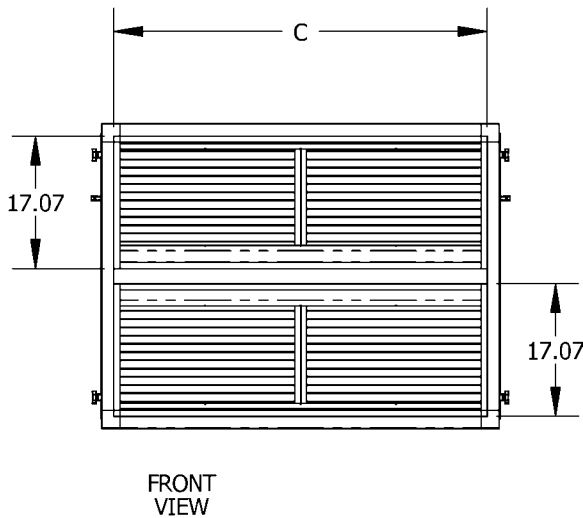
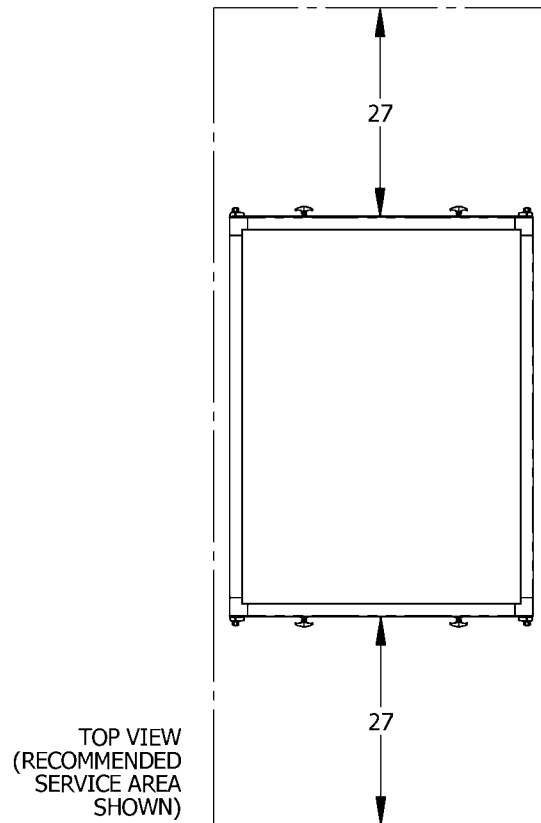
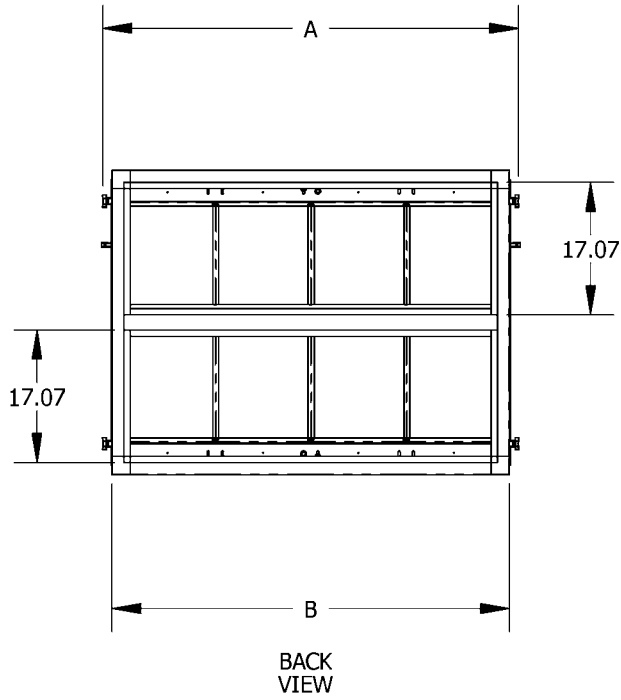

D Series → Model i-FSS-xSHHHH

A standard-height indoor system offering a flexible duct connection pattern and integrated blowers supplying a wide range of pressures and flows. Construction is aluminum space frame with corrosion-resistant hardware and double-walled coated aluminum panels, whose closed-cell foam insulation results in a 5.7 R-value.

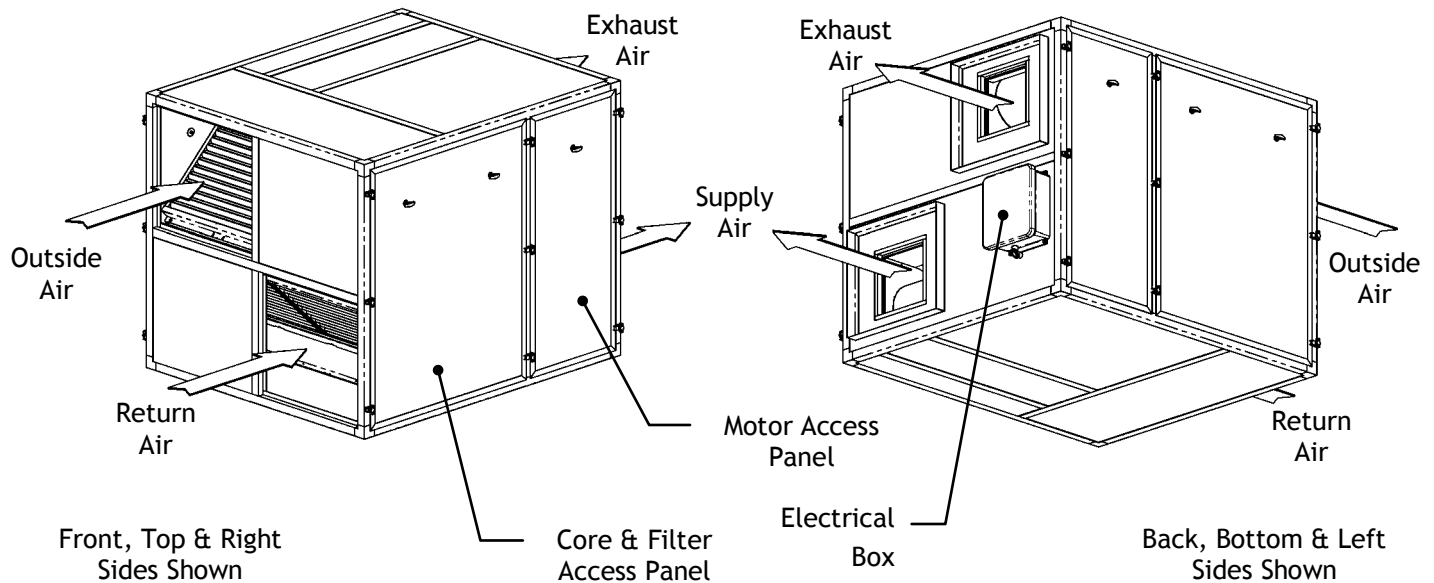

D2i-FSS -xSHHHH	ESP [in-H ₂ O]		Max Weight = 367 lb		D3i-FSS -xSHHHH	ESP [in-H ₂ O]		Max Weight = 459 lb					
	0	0.5	1	1.5		0	0.5	1	1.5				
	Airflow	600	1/2 hp	1/2 hp		1/2 hp	3/4 hp	Airflow	800	1/2 hp	1/2 hp	3/4 hp	3/4 hp
	[SCFM]	900	1/2 hp	1 hp		1 hp	1.5 hp	[SCFM]	1200	1/2 hp	3/4 hp	1 hp	1.5 hp
		1000	1/2 hp	3/4 hp		1.5 hp	1.5 hp		1500	3/4 hp	1 hp	1.5 hp	2 hp
	1200	1 hp	1 hp	1.5 hp	2 hp		1800	1.5 hp	1.5 hp	2 hp	2 hp		
D4i-FSS -xSHHHH	ESP [in-H ₂ O]		Max Weight = 545 lb		D5i-FSS -xSHHHH	ESP [in-H ₂ O]		Max Weight = 633 lb					
	0	0.5	1	1.5		0	0.5	1	1.5				
	Airflow	1000	1/2 hp	1/2 hp		3/4 hp	1 hp	Airflow	1500	1/2 hp	3/4 hp	1 hp	1.5 hp
	[SCFM]	1800	1 hp	1.5 hp		1.5 hp	2 hp	[SCFM]	2000	1 hp	1.5 hp	2 hp	2 hp
		2000	1.5 hp	1.5 hp		2 hp	3 hp		2500	1.5 hp	3 hp	3 hp	3 hp
	2400	1.5 hp	3 hp	3 hp	3 hp		3000	3 hp	3 hp	5 hp	5 hp		
D6i-FSS -xSHHHH	ESP [in-H ₂ O]		Max Weight = 725 lb		D7i-FSS -xSHHHH	ESP [in-H ₂ O]		Max Weight = 835 lb					
	0	0.5	1	1.5		0	0.5	1	1.5				
	Airflow	1800	3/4 hp	1 hp		1.5 hp	1.5 hp	Airflow	2000	3/4 hp	1.5 hp	1.5 hp	2 hp
	[SCFM]	2400	1.5 hp	2 hp		3 hp	3 hp	[SCFM]	3000	2 hp	3 hp	3 hp	3 hp
		3000	2 hp	3 hp		3 hp	5 hp		3500	3 hp	5 hp	5 hp	5 hp
	3400	3 hp	5 hp	5 hp	5 hp		4000	3 hp	5 hp	5 hp	7.5 hp		
D8i-FSS -xSHHHH	ESP [in-H ₂ O]		Max Weight = 915 lb		D9i-fss -xSHHHH	ESP [in-H ₂ O]		Max Weight = 1003 lb					
	0	0.5	1	1.5		0	0.5	1	1.5				
	Airflow	3000	1.5 hp	3 hp		3 hp	3 hp	Airflow	3500	2 hp	3 hp	3 hp	5 hp
	[SCFM]	3500	2 hp	3 hp		3 hp	5 hp	[SCFM]	4000	3 hp	3 hp	5 hp	5 hp
		4000	3 hp	5 hp		5 hp	5 hp		4500	5 hp	5 hp	5 hp	5 hp
	4500	5 hp	5 hp	5 hp	7.5 hp		5000	5 hp	7.5 hp	7.5 hp	7.5 hp		

# CORES	MODEL #	A	B	C	D
2	D2i - FSS	29.18	26.72	11	10
3	D3i - FSS	41.52	39.06	17.17	15
4	D4i - FSS	53.87	51.41	23.34	21
5	D5i - FSS	66.21	63.75	29.51	27
6	D6i - FSS	78.55	76.09	35.68	33
7	D7i - FSS	90.9	88.44	41.86	39
8	D8i - FSS	103.24	100.78	48.03	45
9	D9i - FSS	115.59	113.13	54.2	51

NOTES:

SYSTEM IS INTENDED FOR INDOOR USE ONLY

OA - OUTSIDE AIR INTAKE
 SA - SUPPLY AIR EXIT
 RA - RETURN AIR INTAKE
 EA - EXHAUST AIR EXIT

OA & RA INPUTS CAN BE SWITCHED UPON REQUEST,
 CAUSING SA & EA TO REVERSE POSITIONS

D4i-FSS-xSHHHH MODEL PICTURED

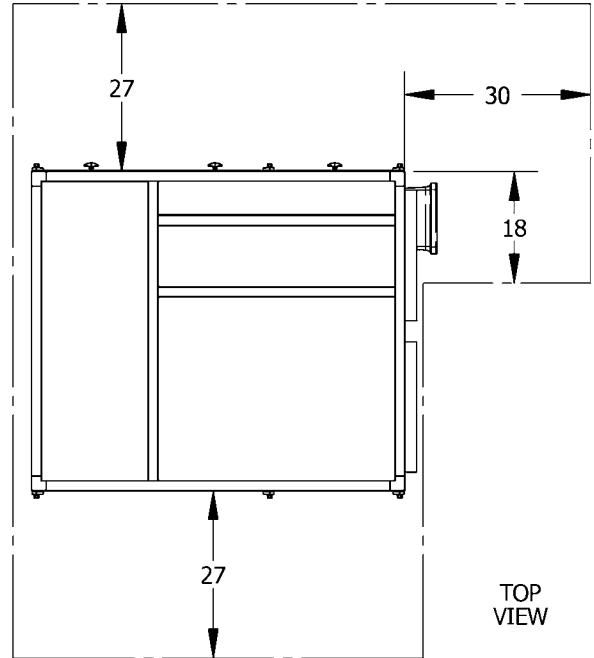
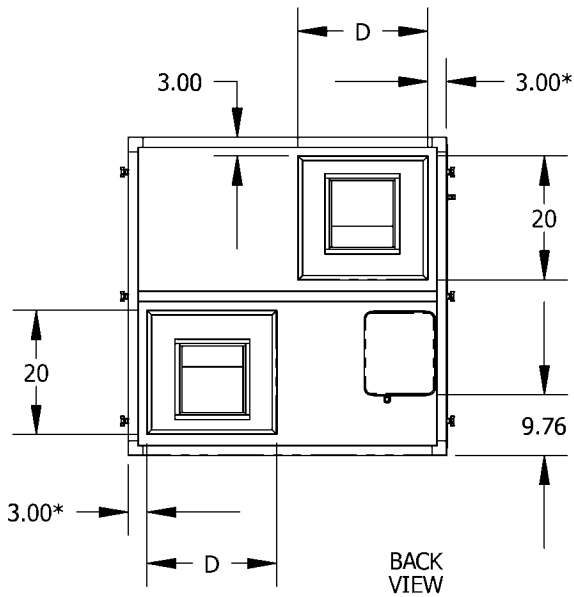

RECOMMENDED SERVICE AREA SHOWN

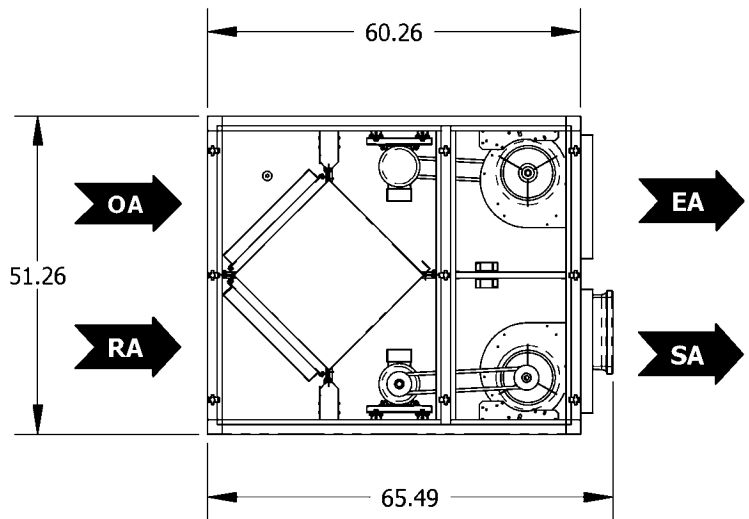
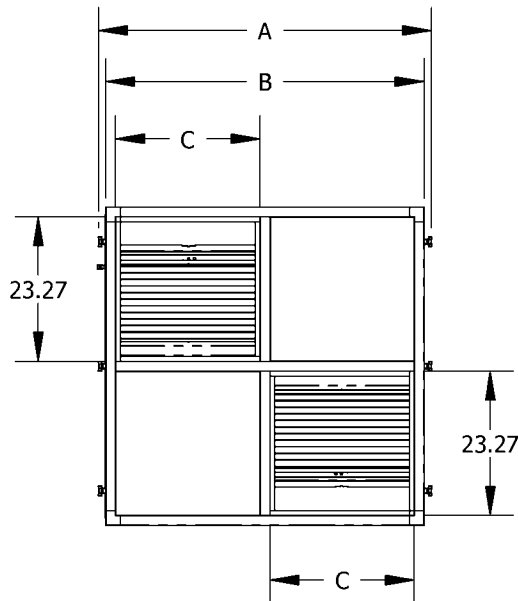

* THESE DIMENSIONS ARE REDUCED TO 2.00 FOR THE D2i-FSS-xSHHHH MODEL

D Series → Model i-FSE-xSHHHH

A standard-height indoor system with extended duct connections and integrated blowers supplying a wide range of pressures and flows. Construction is aluminum space frame with corrosion-resistant hardware and double-walled coated aluminum panels, whose closed-cell foam insulation results in a 5.7 R-value.

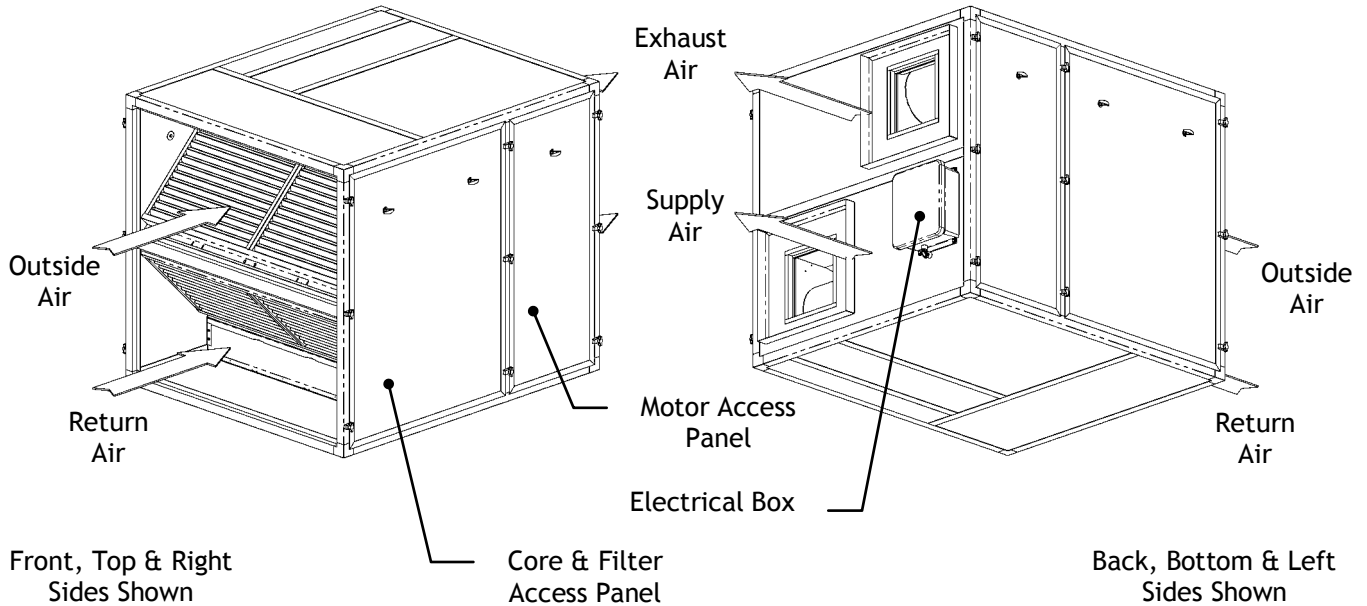

D2i-FSE -xSHHHH	ESP [in-H ₂ O]				Max Weight = 358 lb	D3i-FSE -xSHHHH	ESP [in-H ₂ O]				Max Weight = 448 lb
	0	0.5	1	1.5			0	0.5	1	1.5	
Airflow	500	1/2 hp	1/2 hp	1/2 hp	1/2 hp	800	1/2 hp	1/2 hp	3/4 hp	3/4 hp	
[SCFM]	900	1/2 hp	1/2 hp	1 hp	1.5 hp	1200	1/2 hp	3/4 hp	1 hp	1.5 hp	
	1000	1/2 hp	3/4 hp	1.5 hp	1.5 hp	1500	3/4 hp	1 hp	1.5 hp	1.5 hp	
	1200	3/4 hp	1 hp	1.5 hp	1.5 hp	1800	1 hp	1.5 hp	2 hp	2 hp	

D4i-FSE -xSHHHH	ESP [in-H ₂ O]				Max Weight = 532 lb	D5i-FSE -xSHHHH	ESP [in-H ₂ O]				Max Weight = 630 lb
	0	0.5	1	1.5			0	0.5	1	1.5	
Airflow	1000	1/2 hp	1/2 hp	3/4 hp	3/4 hp	1500	1/2 hp	3/4 hp	1 hp	1.5 hp	
[SCFM]	1800	3/4 hp	1 hp	1.5 hp	2 hp	2000	3/4 hp	1 hp	1.5 hp	2 hp	
	2000	1 hp	1.5 hp	1.5 hp	2 hp	2500	1 hp	1.5 hp	2 hp	3 hp	
	2400	1.5 hp	2 hp	3 hp	3 hp	3000	2 hp	3 hp	3 hp	5 hp	

D6i-FSE -xSHHHH	ESP [in-H ₂ O]				Max Weight = 708 lb	D7i-FSE -xSHHHH	ESP [in-H ₂ O]				Max Weight = 794 lb
	0	0.5	1	1.5			0	0.5	1	1.5	
Airflow	1800	1/2 hp	3/4 hp	1.5 hp	1.5 hp	2000	1/2 hp	1 hp	1.5 hp	1.5 hp	
[SCFM]	2400	1 hp	1.5 hp	2 hp	3 hp	3000	1.5 hp	2 hp	3 hp	3 hp	
	3000	1.5 hp	2 hp	3 hp	3 hp	3500	2 hp	3 hp	3 hp	5 hp	
	3400	2 hp	3 hp	5 hp	5 hp	4000	3 hp	3 hp	5 hp	5 hp	

D8i-FSE -xSHHHH	ESP [in-H ₂ O]				Max Weight = 872 lb	D9i-FSE -xSHHHH	ESP [in-H ₂ O]				Max Weight = 980 lb
	0	0.5	1	1.5			0	0.5	1	1.5	
Airflow	3000	1.5 hp	1.5 hp	3 hp	3 hp	3500	1.5 hp	2 hp	3 hp	5 hp	
[SCFM]	3500	2 hp	2 hp	3 hp	5 hp	4000	3 hp	3 hp	5 hp	5 hp	
	4000	3 hp	3 hp	5 hp	5 hp	4500	3 hp	5 hp	5 hp	5 hp	
	4500	5 hp	5 hp	5 hp	5 hp	5000	7.5 hp	5 hp	5 hp	7.5 hp	

# CORES	MODEL #	A	B	C	D
2	D2i - FSE	29.18	26.72	23.57	10
3	D3i - FSE	41.52	39.06	35.91	15
4	D4i - FSE	53.87	51.41	48.26	21
5	D5i - FSE	66.21	63.75	60.60	27
6	D6i - FSE	78.55	76.09	72.94	33
7	D7i - FSE	90.9	88.44	85.29	39
8	D8i - FSE	103.24	100.78	97.63	45
9	D9i - FSE	115.59	113.13	109.98	51

NOTES:

SYSTEM IS INTENDED FOR INDOOR USE ONLY

OA - OUTSIDE AIR INTAKE
 SA - SUPPLY AIR EXIT
 RA - RETURN AIR INTAKE
 EA - EXHAUST AIR EXIT

OA & RA INPUTS CAN BE SWITCHED UPON REQUEST,
 CAUSING SA & EA TO REVERSE POSITIONS

D4i-FSE-xSHHHH MODEL PICTURED

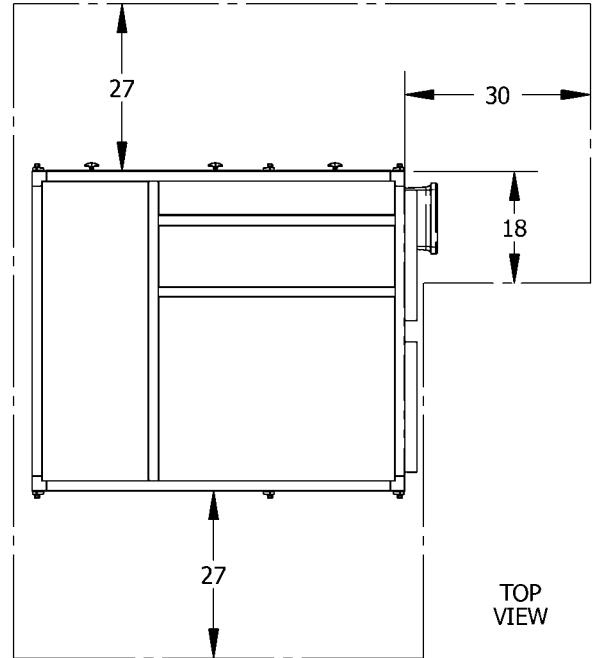
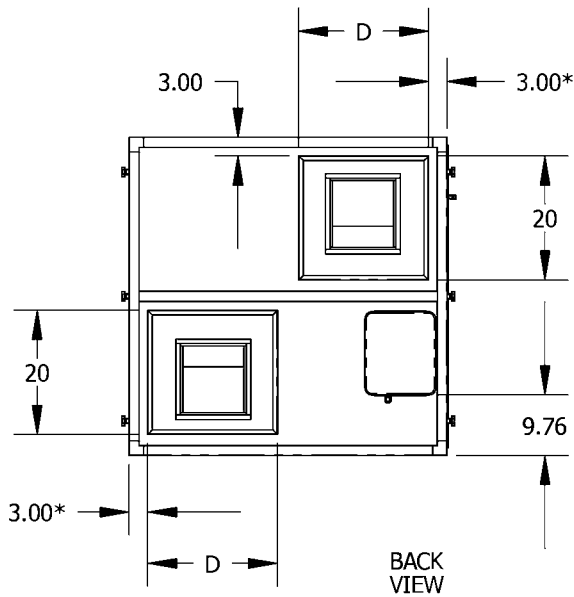

RECOMMENDED SERVICE AREA SHOWN

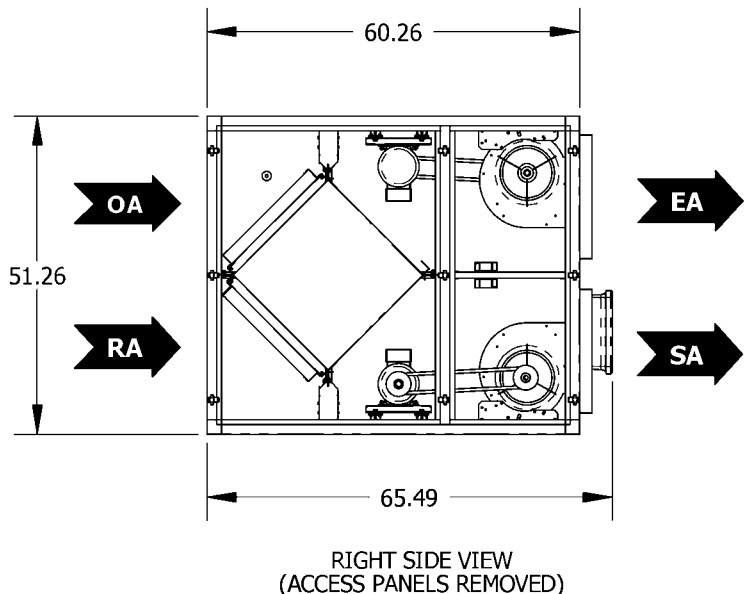
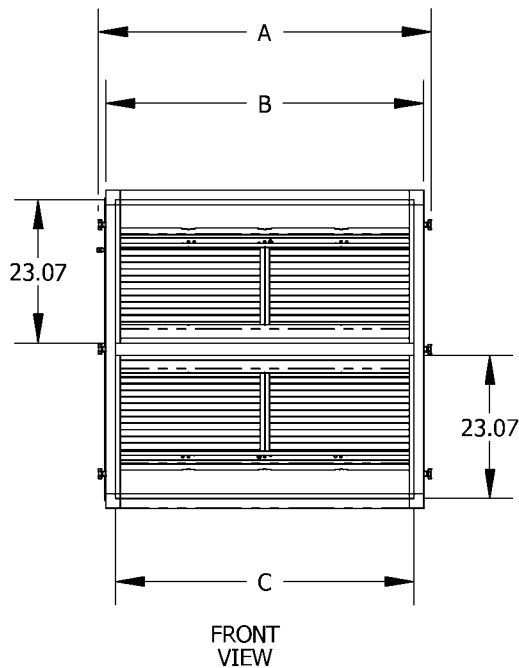

* THESE DIMENSIONS ARE REDUCED TO 2.00 FOR THE D2i-FSS-xSHHHH MODEL

D Series → Model i-FSE-xTHHHH

A standard-height indoor system with extended duct connections and integrated blowers supplying a wide range of pressures and flows. The box is rotated 90 degrees to allow a counterflow configuration where outside air and return air travel in opposite directions. Construction is aluminum frame with corrosion-resistant hardware and double-walled coated aluminum panels, whose closed-cell foam insulation results in a 5.7 R-value.

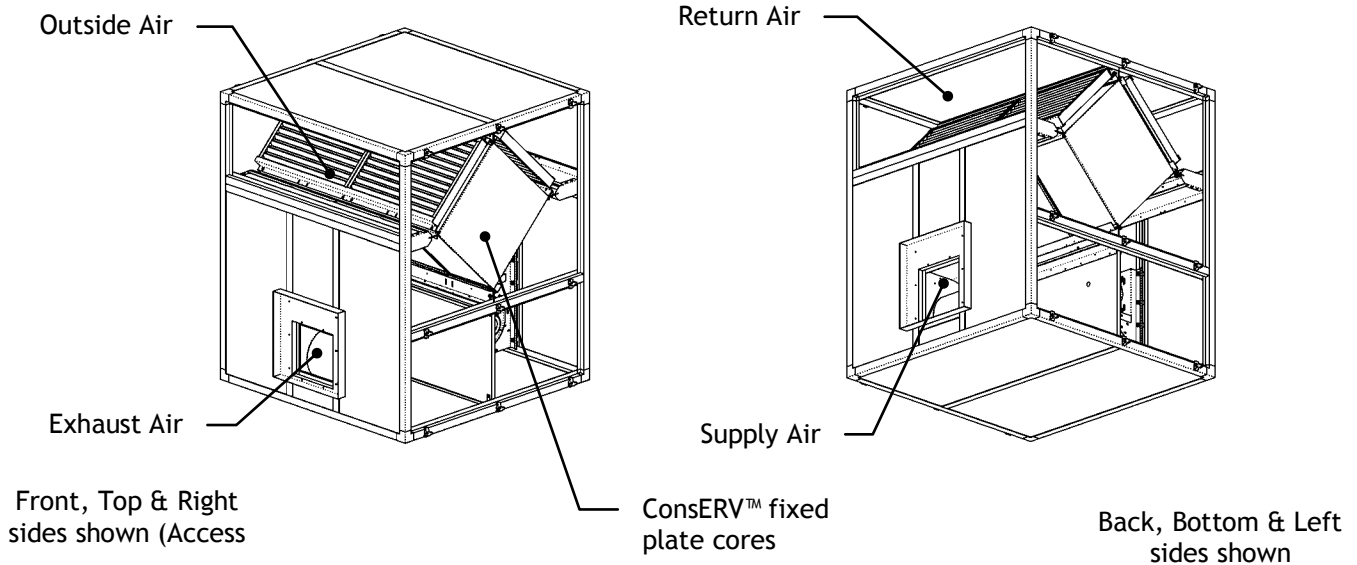

D2i-FSE -xTHHHH	ESP [in-H ₂ O]				Max Weight = 358 lb	D3i-FSE -xTHHHH	ESP [in-H ₂ O]				Max Weight = 448 lb
	0	0.5	1	1.5			0	0.5	1	1.5	
Airflow	500	1/2 hp	1/2 hp	1/2 hp	1/2 hp	800	1/2 hp	1/2 hp	3/4 hp	3/4 hp	
[SCFM]	900	1/2 hp	1/2 hp	1 hp	1.5 hp	1200	1/2 hp	3/4 hp	1 hp	1.5 hp	
	1000	1/2 hp	3/4 hp	1.5 hp	1.5 hp	1500	3/4 hp	1 hp	1.5 hp	1.5 hp	
	1200	3/4 hp	1 hp	1.5 hp	1.5 hp	1800	1 hp	1.5 hp	2 hp	2 hp	
D4i-FSE -xTHHHH	ESP [in-H ₂ O]				Max Weight = 532 lb	D5i-FSE -xTHHHH	ESP [in-H ₂ O]				Max Weight = 630 lb
	0	0.5	1	1.5			0	0.5	1	1.5	
Airflow	1000	1/2 hp	1/2 hp	3/4 hp	3/4 hp	1500	1/2 hp	3/4 hp	1 hp	1.5 hp	
[SCFM]	1800	3/4 hp	1 hp	1.5 hp	2 hp	2000	3/4 hp	1 hp	1.5 hp	2 hp	
	2000	1 hp	1.5 hp	1.5 hp	2 hp	2500	1 hp	1.5 hp	2 hp	3 hp	
	2400	1.5 hp	2 hp	3 hp	3 hp	3000	2 hp	3 hp	3 hp	5 hp	
D6i-FSE -xTHHHH	ESP [in-H ₂ O]				Max Weight = 708 lb	D7i-FSE -xTHHHH	ESP [in-H ₂ O]				Max Weight = 794 lb
	0	0.5	1	1.5			0	0.5	1	1.5	
Airflow	1800	1/2 hp	3/4 hp	1.5 hp	1.5 hp	2000	1/2 hp	1 hp	1.5 hp	1.5 hp	
[SCFM]	2400	1 hp	1.5 hp	2 hp	3 hp	3000	1.5 hp	2 hp	3 hp	3 hp	
	3000	1.5 hp	2 hp	3 hp	3 hp	3500	2 hp	3 hp	3 hp	5 hp	
	3400	2 hp	3 hp	5 hp	5 hp	4000	3 hp	3 hp	5 hp	5 hp	
D8i-FSE -xTHHHH	ESP [in-H ₂ O]				Max Weight = 872 lb	D9i-FSE -xTHHHH	ESP [in-H ₂ O]				Max Weight = 980 lb
	0	0.5	1	1.5			0	0.5	1	1.5	
Airflow	3000	1.5 hp	1.5 hp	3 hp	3 hp	3500	1.5 hp	2 hp	3 hp	5 hp	
[SCFM]	3500	2 hp	2 hp	3 hp	5 hp	4000	3 hp	3 hp	5 hp	5 hp	
	4000	3 hp	3 hp	5 hp	5 hp	4500	3 hp	5 hp	5 hp	5 hp	
	4500	5 hp	5 hp	5 hp	5 hp	5400	7.5 hp	5 hp	5 hp	7.5 hp	

# CORES	MODEL #	A	B	C
2	D2i - FSE-xTHHHH	29.18	26.72	23.57
3	D3i - FSE-xTHHHH	41.52	39.06	35.91
4	D4i - FSE-xTHHHH	53.87	51.41	48.26
5	D5i - FSE-xTHHHH	66.21	63.75	60.60
6	D6i - FSE-xTHHHH	78.55	76.09	72.94
7	D7i - FSE-xTHHHH	90.9	88.44	85.29
8	D8i - FSE-xTHHHH	103.24	100.78	97.63
9	D9i - FSE-xTHHHH	115.59	113.13	109.98

NOTES:

SYSTEM IS INTENDED FOR INDOOR USE ONLY

OA - OUTSIDE AIR INTAKE
 SA - SUPPLY AIR EXIT
 RA - RETURN AIR INTAKE
 EA - EXHAUST AIR EXIT

OA & RA INPUTS CAN BE SWITCHED UPON REQUEST,
 CAUSING SA & EA TO REVERSE POSITIONS

D4i-FSE-xTHHHH MODEL PICTURED

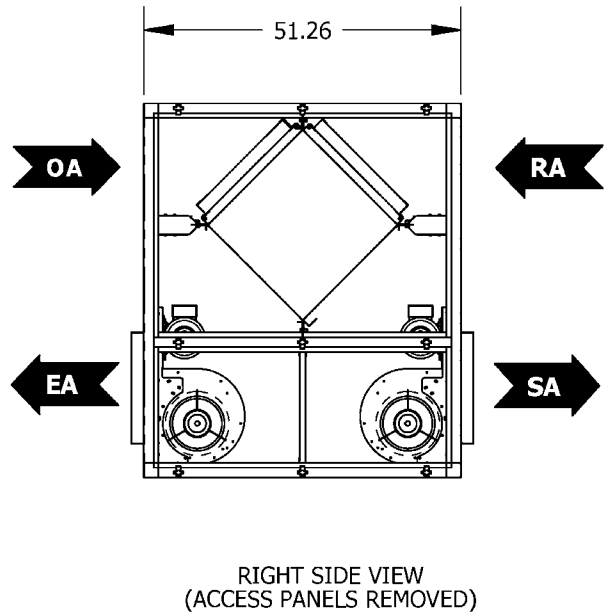
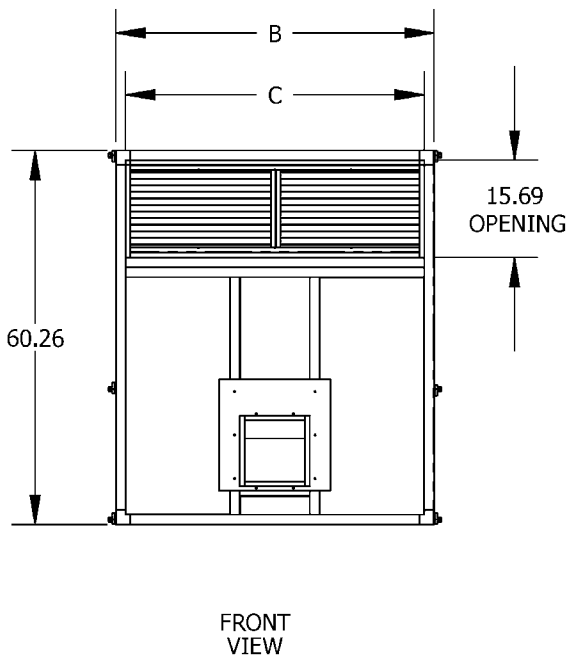
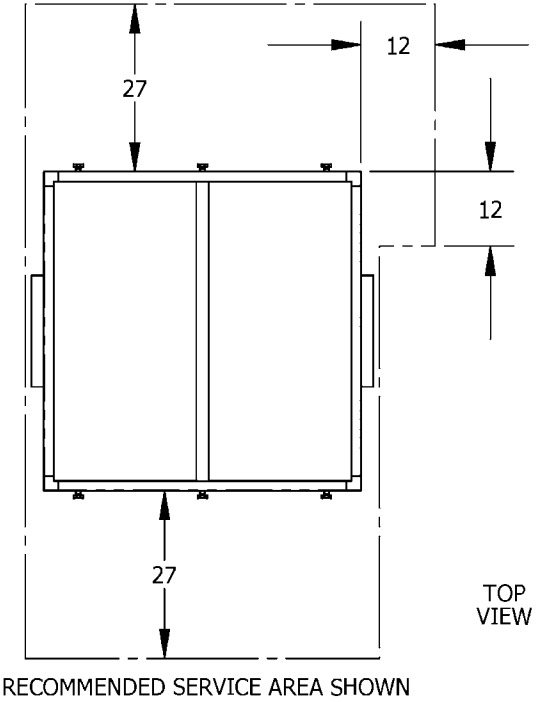
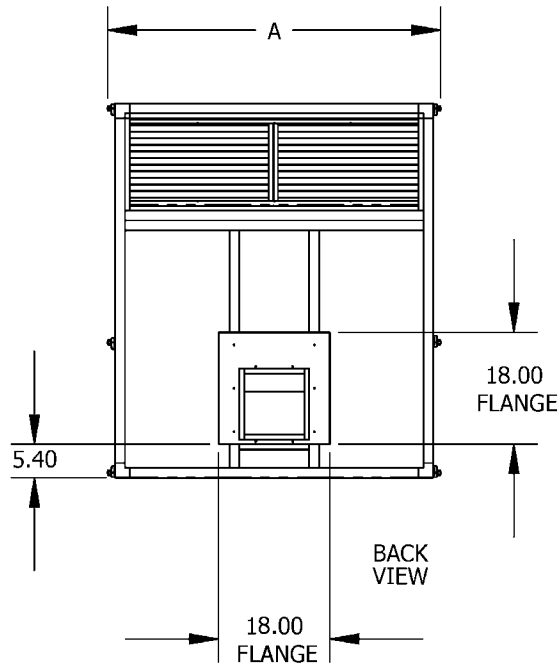

D Series → Model i-FSS-xSHSHS

A standard-height indoor system with extended duct connections and integrated blowers supplying a wide range of pressures and flows. Construction is aluminum space frame with corrosion-resistant hardware and double-walled coated aluminum panels, whose closed-cell foam insulation results in a 5.7 R-value.

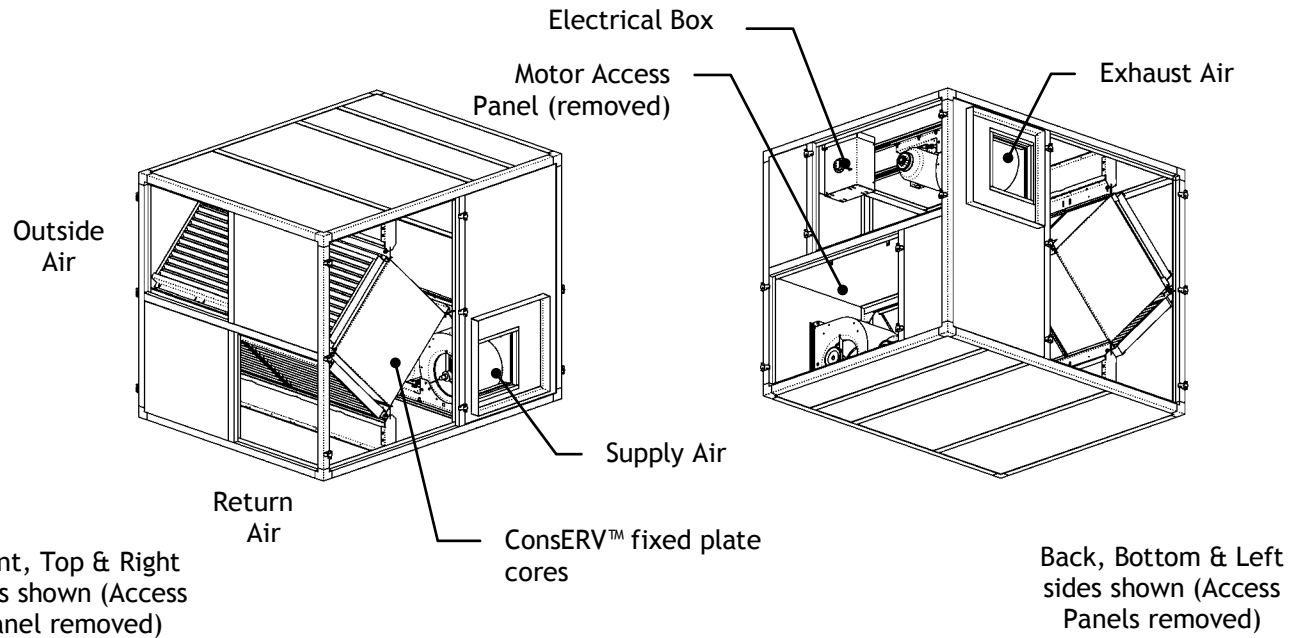

Model	ESP [in-H ₂ O]				Max Weight =	Model	ESP [in-H ₂ O]				
	0	0.5	1	1.5			0	0.5	1	1.5	
D2i-FSS-xSHSHS					367 lb	D3i-FSS-xSHSHS					459 lb
Airflow	1/2 hp	1/2 hp	1/2 hp	3/4 hp		800	1/2 hp	1/2 hp	3/4 hp	3/4 hp	
[SCFM]	1/2 hp	1 hp	1 hp	1.5 hp		1200	1/2 hp	3/4 hp	1 hp	1.5 hp	
	1/2 hp	3/4 hp	1.5 hp	1.5 hp		1500	3/4 hp	1 hp	1.5 hp	2 hp	
	1 hp	1 hp	1.5 hp	2 hp		1800	1.5 hp	1.5 hp	2 hp	2 hp	
D4i-FSS-xSHSHS					545 lb	D5i-FSS-xSHSHS					633 lb
Airflow	1/2 hp	1/2 hp	3/4 hp	1 hp		1500	1/2 hp	3/4 hp	1 hp	1.5 hp	
[SCFM]	1 hp	1.5 hp	1.5 hp	2 hp		2000	1 hp	1.5 hp	2 hp	2 hp	
	1.5 hp	1.5 hp	2 hp	3 hp		2500	1.5 hp	3 hp	3 hp	3 hp	
	1.5 hp	3 hp	3 hp	3 hp		3000	3 hp	3 hp	5 hp	5 hp	
D6i-FSS-xSHSHS					725 lb	D7i-FSS-xSHSHS					835 lb
Airflow	3/4 hp	1 hp	1.5 hp	1.5 hp		2000	3/4 hp	1.5 hp	1.5 hp	2 hp	
[SCFM]	1.5 hp	2 hp	3 hp	3 hp		3000	2 hp	3 hp	3 hp	3 hp	
	2 hp	3 hp	3 hp	5 hp		3500	3 hp	5 hp	5 hp	5 hp	
	3 hp	5 hp	5 hp	5 hp		4000	3 hp	5 hp	5 hp	7.5 hp	
D8i-FSS-xSHSHS					915 lb	D9i-FSS-xSHSHS					1003 lb
Airflow	1.5 hp	3 hp	3 hp	3 hp		3500	2 hp	3 hp	3 hp	5 hp	
[SCFM]	2 hp	3 hp	3 hp	5 hp		4000	3 hp	3 hp	5 hp	5 hp	
	3 hp	5 hp	5 hp	5 hp		4500	5 hp	5 hp	5 hp	5 hp	
	5 hp	5 hp	5 hp	7.5 hp		5000	5 hp	7.5 hp	7.5 hp	7.5 hp	

# CORES	MODEL #	A	B	C
2	D2i - FSS-xSHSHS	29.18	26.72	11
3	D3i - FSS-xSHSHS	41.52	39.06	17.17
4	D4i - FSS-xSHSHS	53.87	51.41	23.34
5	D5i - FSS-xSHSHS	66.21	63.75	29.51
6	D6i - FSS-xSHSHS	78.55	76.09	35.68
7	D7i - FSS-xSHSHS	90.9	88.44	41.86
8	D8i - FSS-xSHSHS	103.24	100.78	48.03
9	D9i - FSS-xSHSHS	115.59	113.13	54.2

NOTES:

SYSTEM IS INTENDED FOR INDOOR USE ONLY

OA - OUTSIDE AIR INTAKE
 SA - SUPPLY AIR EXIT
 RA - RETURN AIR INTAKE
 EA - EXHAUST AIR EXIT

OA & RA INPUTS CAN BE SWITCHED UPON REQUEST,
 CAUSING SA & EA TO REVERSE POSITIONS

D4i-FSS-xSHSHS MODEL PICTURED

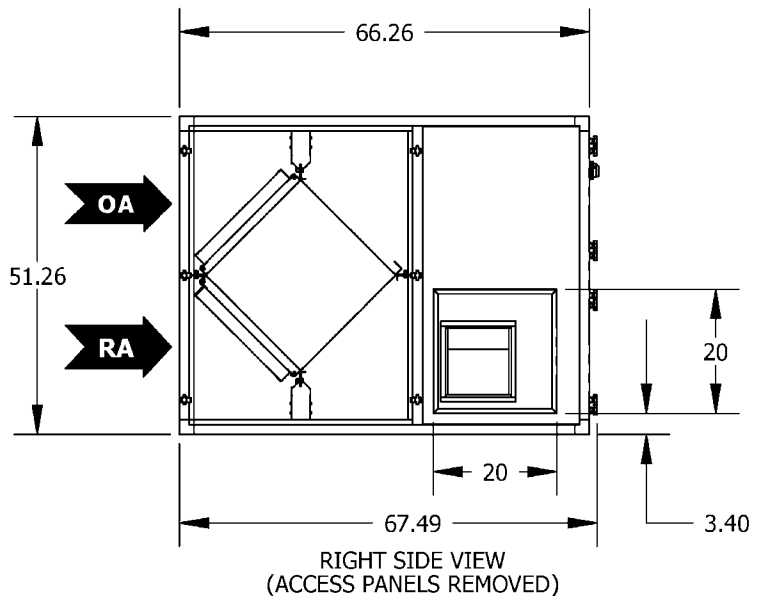
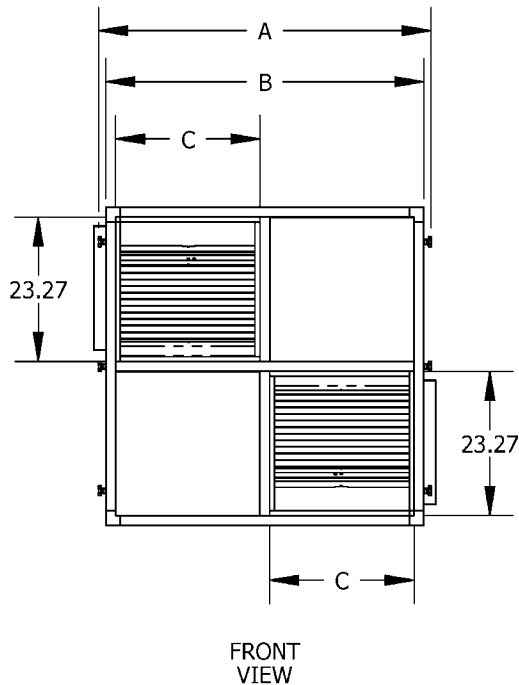
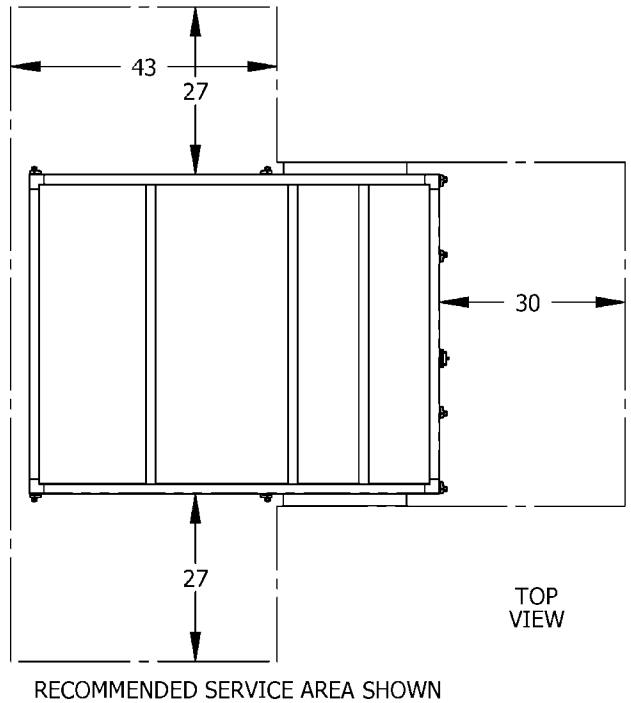
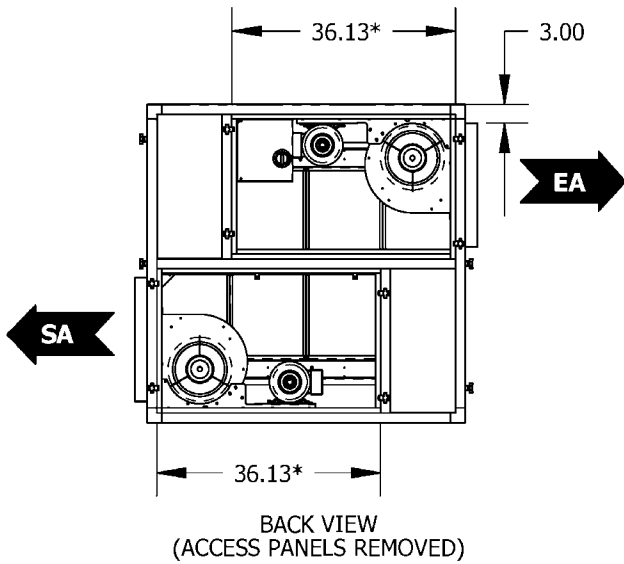

* ACCESS PANELS COVER ENTIRE WIDTH FOR D2i-FSS-xSHSHS AND D3i-FSS-xSHSHS

D Series → Model R-FSE-xSHVVH

A rooftop system with integrated blowers designed to be mounted on a roof curb and direct its return and supply air flows vertically through the curb. Construction is aluminum space frame with corrosion-resistant hardware and double-walled coated aluminum panels, whose closed-cell foam insulation results in a 5.7 R-value.

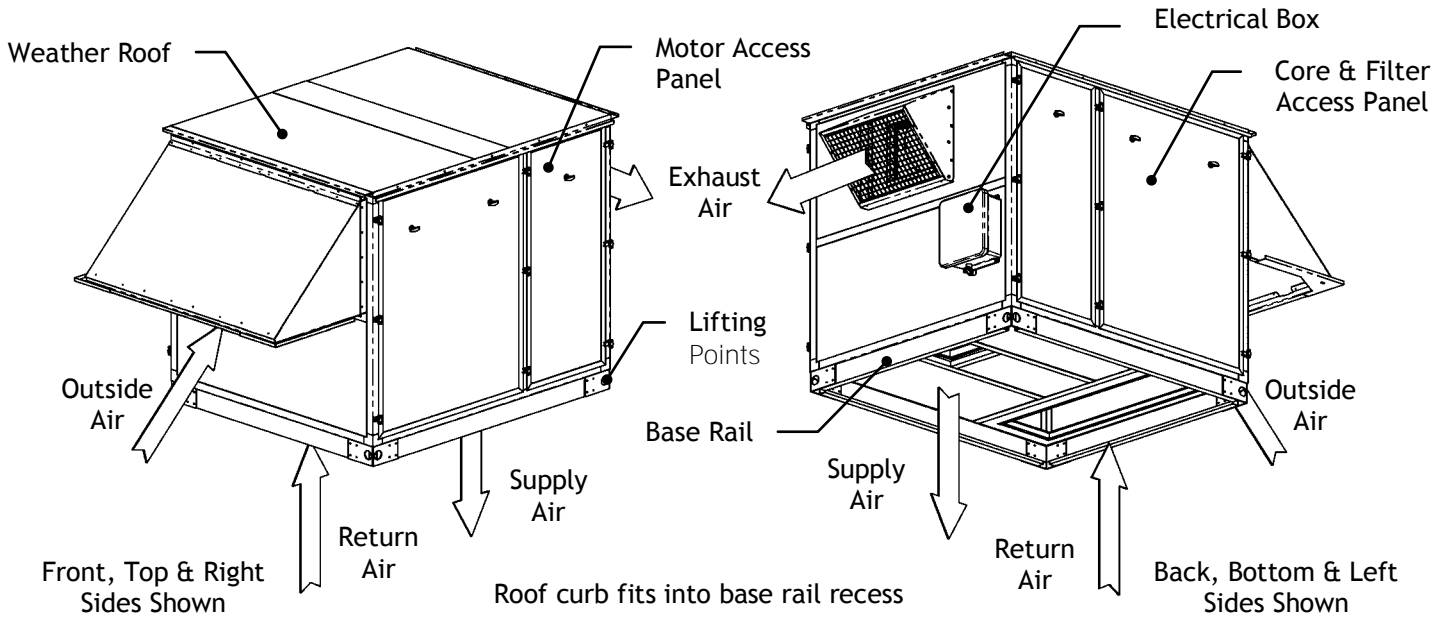

D2R-FSE -xSHVVH	ESP [in-H ₂ O]				Max Weight = 435 lb	D3R-FSE -xSHVVH	ESP [in-H ₂ O]				Max Weight = 532 lb
	0	0.5	1	1.5			0	0.5	1	1.5	
Airflow	600	1/2 hp	1/2 hp	1/2 hp	3/4 hp	800	1/2 hp	1/2 hp	3/4 hp	3/4 hp	
[SCFM]	900	1/2 hp	1/2 hp	1 hp	1.5 hp	1200	1/2 hp	3/4 hp	1 hp	1.5 hp	
	1000	1/2 hp	3/4 hp	1.5 hp	1.5 hp	1500	3/4 hp	1 hp	1.5 hp	1.5 hp	
	1200	1 hp	1 hp	1.5 hp	1.5 hp	1800	1.5 hp	1.5 hp	2 hp	2 hp	
D4R-FSE -xSHVVH	ESP [in-H ₂ O]				Max Weight = 623 lb	D5R-FSE -xSHVVH	ESP [in-H ₂ O]				Max Weight = 728 lb
	0	0.5	1	1.5			0	0.5	1	1.5	
Airflow	1000	1/2 hp	1/2 hp	3/4 hp	3/4 hp	1500	1/2 hp	3/4 hp	1 hp	1.5 hp	
[SCFM]	1800	3/4 hp	1.5 hp	1.5 hp	2 hp	2000	1 hp	1.5 hp	1.5 hp	2 hp	
	2000	1 hp	1.5 hp	2 hp	2 hp	2500	1.5 hp	2 hp	2 hp	3 hp	
	2400	1.5 hp	2 hp	3 hp	3 hp	3000	2 hp	3 hp	3 hp	5 hp	
D6R-FSE -xSHVVH	ESP [in-H ₂ O]				Max Weight = 813 lb	D7R-FSE -xSHVVH	ESP [in-H ₂ O]				Max Weight = 898 lb
	0	0.5	1	1.5			0	0.5	1	1.5	
Airflow	1800	1/2 hp	3/4 hp	1.5 hp	1.5 hp	2000	1/2 hp	1 hp	1.5 hp	2 hp	
[SCFM]	2400	1 hp	1.5 hp	2 hp	3 hp	3000	1.5 hp	2 hp	3 hp	3 hp	
	3000	1.5 hp	3 hp	3 hp	3 hp	3500	2 hp	3 hp	3 hp	5 hp	
	3400	2 hp	3 hp	5 hp	5 hp	4000	3 hp	3 hp	5 hp	5 hp	
D8R-FSE -xSHVVH	ESP [in-H ₂ O]				Max Weight = 991 lb	D9R-FSE -xSHVVH	ESP [in-H ₂ O]				Max Weight = 1106 lb
	0	0.5	1	1.5			0	0.5	1	1.5	
Airflow	3000	1.5 hp	1.5 hp	3 hp	3 hp	3500	1.5 hp	2 hp	3 hp	5 hp	
[SCFM]	3500	2 hp	3 hp	3 hp	5 hp	4000	3 hp	3 hp	3 hp	5 hp	
	4000	3 hp	3 hp	5 hp	5 hp	4500	3 hp	5 hp	5 hp	5 hp	
	4500	5 hp	5 hp	5 hp	5 hp	5000	5 hp	5 hp	7.5 hp	7.5 hp	

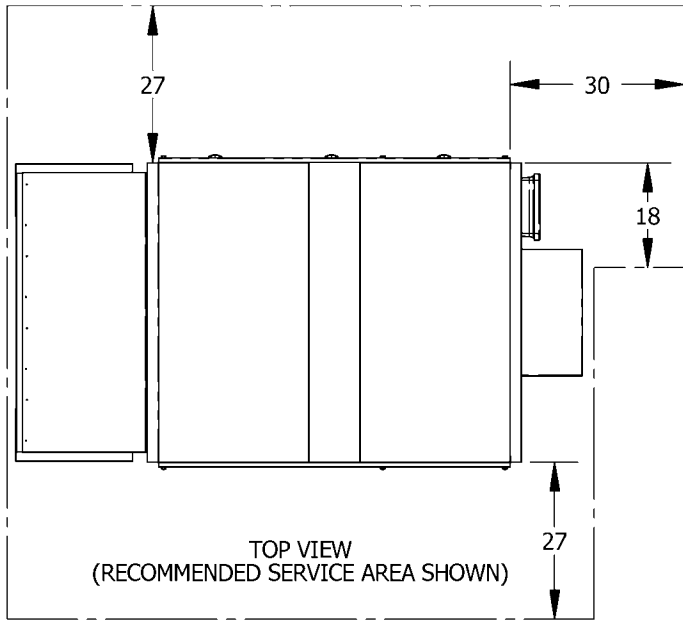

NOTES:

- OA - OUTSIDE AIR INTAKE
- SA - SUPPLY AIR EXIT
- RA - RETURN AIR INTAKE
- EA - EXHAUST AIR EXIT

SYSTEM IS INTENDED FOR OUTDOOR USE

SIZE ROOF CURB TO FIT INTO BASE RAIL RECESS

DESIGN CURB TO MAINTAIN SEPARATION OF RETURN AND SUPPLY AIR STREAMS

FOLLOW ALL APPLICABLE CODES AND DESIGN PRACTICES TO ANCHOR SYSTEM TO ROOF AND CURB

D4R-FSE-xSHVVH MODEL PICTURED

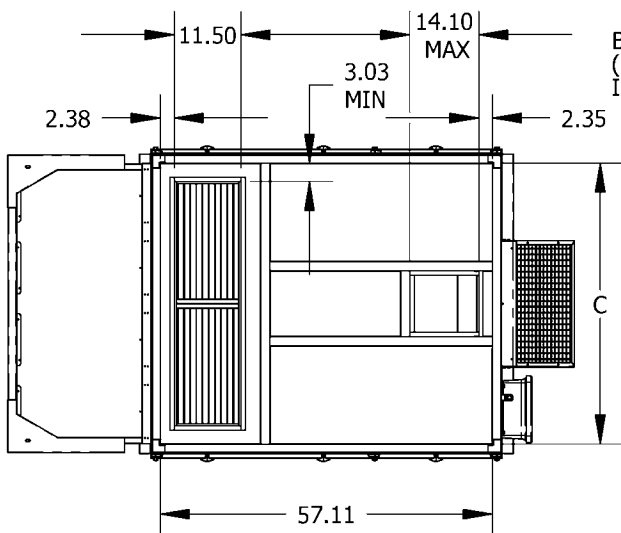
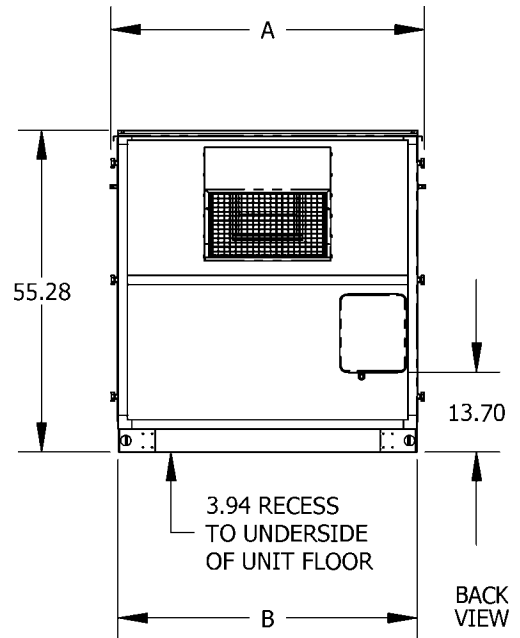
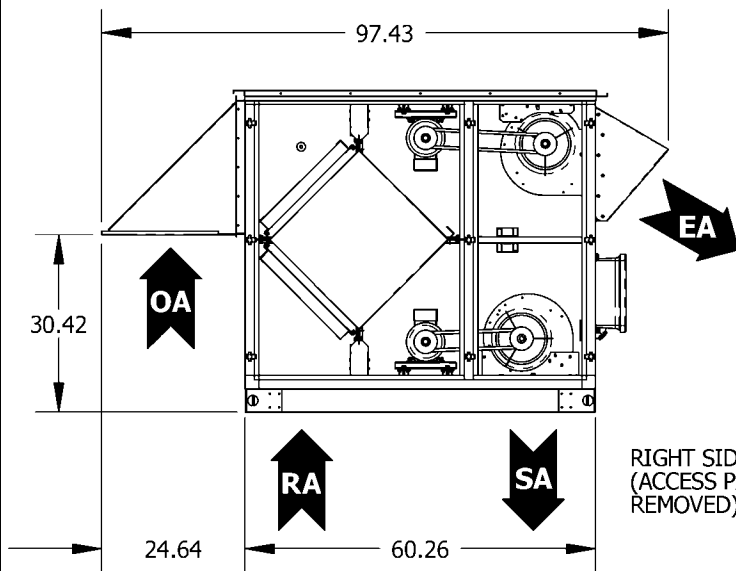

CORES	MODEL #	A	B	C
2	D2R-FSE	29.18	26.72	23.57
3	D3R-FSE	41.52	39.06	35.91
4	D4R-FSE	53.87	51.41	48.26
5	D5R-FSE	66.21	63.75	60.60
6	D6R-FSE	78.55	76.09	72.94
7	D7R-FSE	90.90	88.44	85.29
8	D8R-FSE	103.24	100.78	97.63
9	D9R-FSE	115.59	113.13	109.98

D Series → Model R-FSE-xSHHHH

A rooftop system with integrated blowers designed to direct its return and supply air flows horizontally above the roof. Construction is aluminum space frame with corrosion-resistant hardware and double-walled coated aluminum panels, whose closed-cell foam insulation results in a 5.7 R-value.

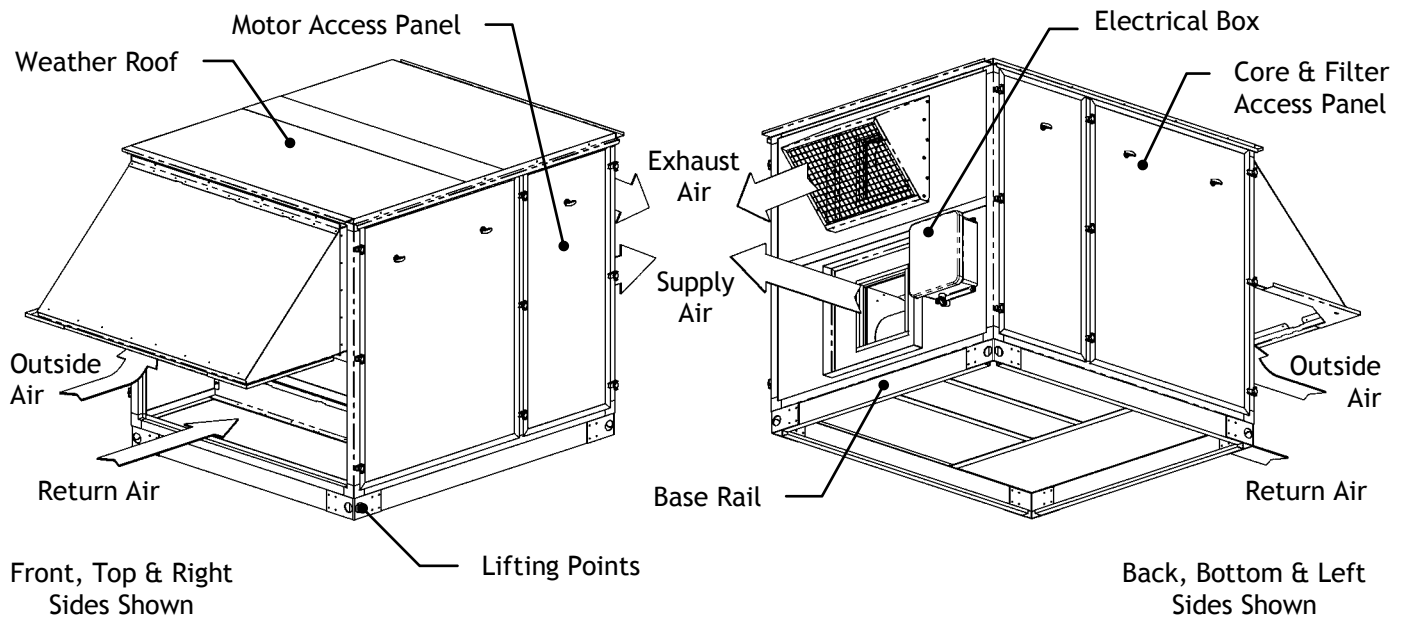

D2R-FSE -xSHHHH	ESP [in-H ₂ O]		Max Weight = 430 lb		D3R-FSE -xSHHHH	ESP [in-H ₂ O]		Max Weight = 526 lb				
	0	0.5	1	1.5		0	0.5	1	1.5			
	Airflow	600	1/2 hp	1/2 hp		1/2 hp	3/4 hp	800	1/2 hp	1/2 hp	3/4 hp	3/4 hp
	[SCFM]	900	1/2 hp	1/2 hp		1 hp	1.5 hp	1200	1/2 hp	3/4 hp	1 hp	1.5 hp
		1000	1/2 hp	3/4 hp		1.5 hp	1.5 hp	1500	3/4 hp	1 hp	1.5 hp	1.5 hp
	1200	1 hp	1 hp	1.5 hp	1.5 hp	1800	1.5 hp	1.5 hp	2 hp	2 hp		
D4R-FSE -xSHHHH	ESP [in-H ₂ O]		Max Weight = 616 lb		D5R-FSE -xSHHHH	ESP [in-H ₂ O]		Max Weight = 720 lb				
	0	0.5	1	1.5		0	0.5	1	1.5			
	Airflow	1000	1/2 hp	1/2 hp		3/4 hp	3/4 hp	1500	1/2 hp	3/4 hp	1 hp	1.5 hp
	[SCFM]	1800	3/4 hp	1.5 hp		1.5 hp	2 hp	2000	1 hp	1.5 hp	1.5 hp	2 hp
		2000	1 hp	1.5 hp		2 hp	2 hp	2500	1.5 hp	2 hp	2 hp	3 hp
	2400	1.5 hp	2 hp	3 hp	3 hp	3000	2 hp	3 hp	3 hp	5 hp		
D6R-FSE -xSHHHH	ESP [in-H ₂ O]		Max Weight = 804 lb		D7R-FSE -xSHHHH	ESP [in-H ₂ O]		Max Weight = 888 lb				
	0	0.5	1	1.5		0	0.5	1	1.5			
	Airflow	1800	1/2 hp	3/4 hp		1.5 hp	1.5 hp	2000	1/2 hp	1 hp	1.5 hp	2 hp
	[SCFM]	2400	1 hp	1.5 hp		2 hp	3 hp	3000	1.5 hp	2 hp	3 hp	3 hp
		3000	1.5 hp	3 hp		3 hp	3 hp	3500	2 hp	3 hp	3 hp	5 hp
	3400	2 hp	3 hp	5 hp	5 hp	4000	3 hp	3 hp	5 hp	5 hp		
D8R-FSE -xSHHHH	ESP [in-H ₂ O]		Max Weight = 980 lb		D9R-FSE -xSHHHH	ESP [in-H ₂ O]		Max Weight = 1094 lb				
	0	0.5	1	1.5		0	0.5	1	1.5			
	Airflow	3000	1.5 hp	1.5 hp		3 hp	3 hp	3500	1.5 hp	2 hp	3 hp	5 hp
	[SCFM]	3500	2 hp	3 hp		3 hp	5 hp	4000	3 hp	3 hp	3 hp	5 hp
		4000	3 hp	3 hp		5 hp	5 hp	4500	3 hp	5 hp	5 hp	5 hp
	4500	5 hp	5 hp	5 hp	5 hp	5000	5 hp	5 hp	7.5 hp	7.5 hp		

CORES	MODEL #	A	B	C	D	E	F
2	D2R-FSE	29.18	26.72	23.57	23.57	10.00	2.38
3	D3R-FSE	41.52	39.06	35.91	35.91	15.00	3.00
4	D4R-FSE	53.87	51.41	48.26	48.26	21.00	14.00
5	D5R-FSE	66.21	63.75	60.60	60.60	27.00	18.38
6	D6R-FSE	78.55	76.09	72.95	72.95	33.00	21.50
7	D7R-FSE	90.90	88.44	85.29	85.29	39.00	24.63
8	D8R-FSE	103.24	100.78	97.63	97.63	45.00	27.88
9	D9R-FSE	115.58	113.13	109.98	109.98	51.00	31.00

NOTES:

OA - OUTSIDE AIR INTAKE
 SA - SUPPLY AIR EXIT
 RA - RETURN AIR INTAKE
 EA - EXHAUST AIR EXIT

SYSTEM IS INTENDED FOR OUTDOOR USE

FOLLOW ALL APPLICABLE CODES AND
 PROPER DESIGN PRACTICES TO
 ANCHOR SYSTEM TO ROOF AND CURB

D4R-FSE-xSHHHH MODEL PICTURED

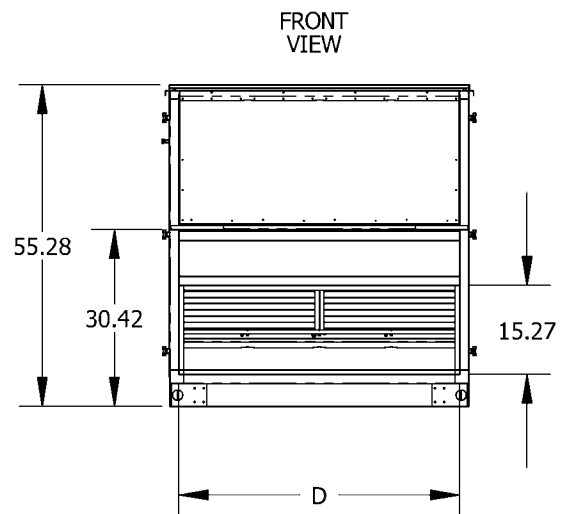
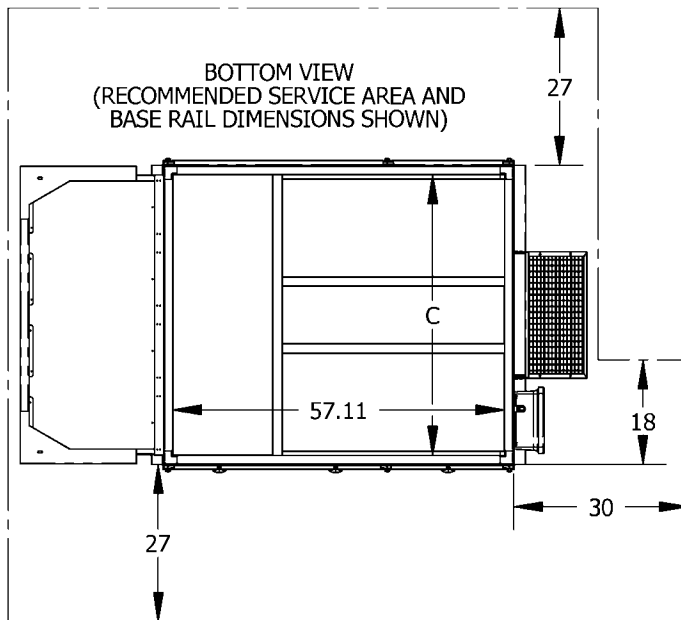
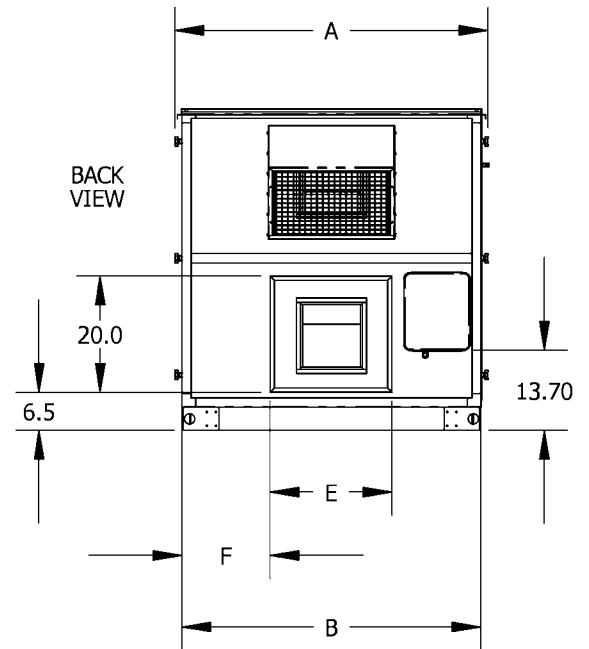
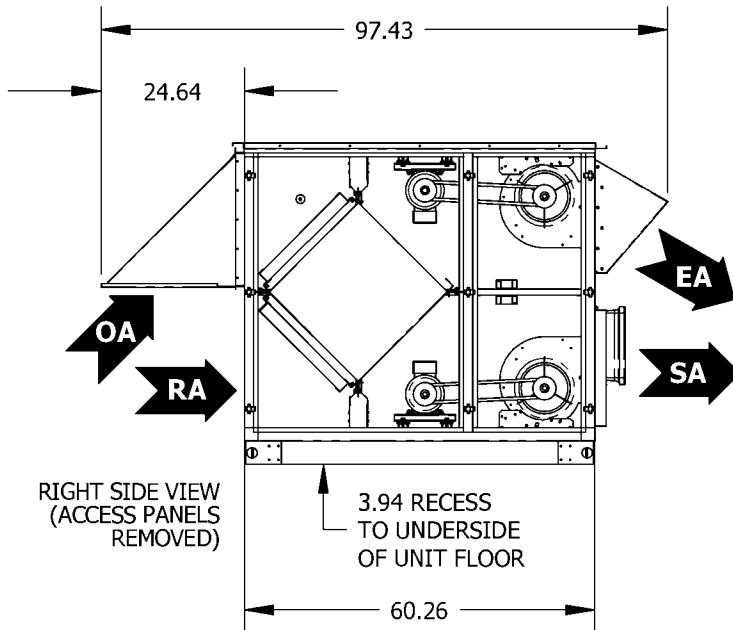

D Series → Model R-FSE-xSHHVH

A rooftop system with integrated blowers designed to bring its return air vertically through a roof curb and supply air horizontally above the roof. Construction is aluminum space frame with corrosion-resistant hardware and double-walled coated aluminum panels, whose closed-cell foam insulation results in a 5.7 R-value.

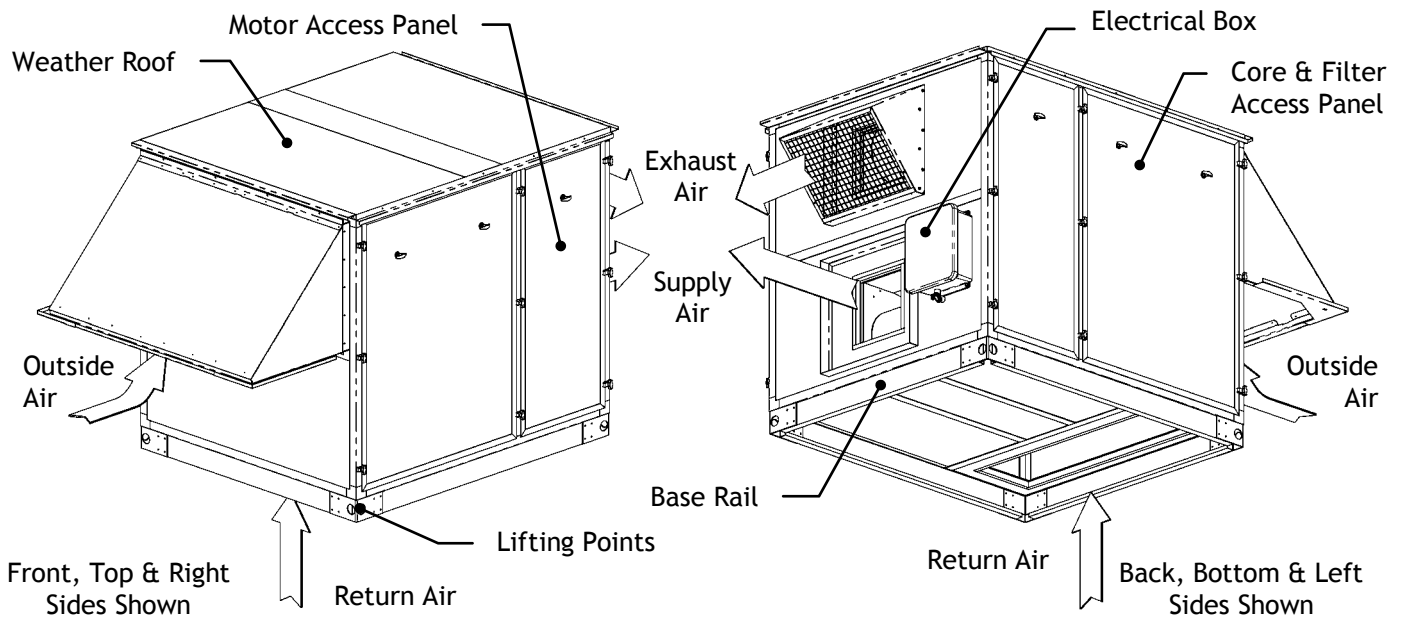

D2R-FSE -xSHHVH	ESP [in-H ₂ O]		Max Weight = 430 lb		D3R-FSE -xSHHVH	ESP [in-H ₂ O]		Max Weight = 526 lb				
	0	0.5	1	1.5		0	0.5	1	1.5			
	Airflow	600	1/2 hp	1/2 hp		1/2 hp	3/4 hp	800	1/2 hp	1/2 hp	3/4 hp	3/4 hp
	[SCFM]	900	1/2 hp	1/2 hp		1 hp	1.5 hp	1200	1/2 hp	3/4 hp	1 hp	1.5 hp
		1000	1/2 hp	3/4 hp		1.5 hp	1.5 hp	1500	3/4 hp	1 hp	1.5 hp	1.5 hp
	1200	1 hp	1 hp	1.5 hp	1.5 hp	1800	1.5 hp	1.5 hp	2 hp	2 hp		
D4R-FSE -xSHHVH	ESP [in-H ₂ O]		Max Weight = 616 lb		D5R-FSE -xSHHVH	ESP [in-H ₂ O]		Max Weight = 720 lb				
	0	0.5	1	1.5		0	0.5	1	1.5			
	Airflow	1000	1/2 hp	1/2 hp		3/4 hp	3/4 hp	1500	1/2 hp	3/4 hp	1 hp	1.5 hp
	[SCFM]	1800	3/4 hp	1.5 hp		1.5 hp	2 hp	2000	1 hp	1.5 hp	1.5 hp	2 hp
		2000	1 hp	1.5 hp		2 hp	2 hp	2500	1.5 hp	2 hp	2 hp	3 hp
	2400	1.5 hp	2 hp	3 hp	3 hp	3000	2 hp	3 hp	3 hp	5 hp		
D6R-FSE -xSHHVH	ESP [in-H ₂ O]		Max Weight = 804 lb		D7R-FSE -xSHHVH	ESP [in-H ₂ O]		Max Weight = 888 lb				
	0	0.5	1	1.5		0	0.5	1	1.5			
	Airflow	1800	1/2 hp	3/4 hp		1.5 hp	1.5 hp	2000	1/2 hp	1 hp	1.5 hp	2 hp
	[SCFM]	2400	1 hp	1.5 hp		2 hp	3 hp	3000	1.5 hp	2 hp	3 hp	3 hp
		3000	1.5 hp	3 hp		3 hp	3 hp	3500	2 hp	3 hp	3 hp	5 hp
	3400	2 hp	3 hp	5 hp	5 hp	4000	3 hp	3 hp	5 hp	5 hp		
D8R-FSE -xSHHVH	ESP [in-H ₂ O]		Max Weight = 980 lb		D9R-FSE -xSHHVH	ESP [in-H ₂ O]		Max Weight = 1094 lb				
	0	0.5	1	1.5		0	0.5	1	1.5			
	Airflow	3000	1.5 hp	1.5 hp		3 hp	3 hp	3500	1.5 hp	2 hp	3 hp	5 hp
	[SCFM]	3500	2 hp	3 hp		3 hp	5 hp	4000	3 hp	3 hp	3 hp	5 hp
		4000	3 hp	3 hp		5 hp	5 hp	4500	3 hp	5 hp	5 hp	5 hp
	4500	5 hp	5 hp	5 hp	5 hp	5000	5 hp	5 hp	7.5 hp	7.5 hp		

CORES	MODEL #	A	B	C	D	E	F
2	D2R-FSE	29.18	26.72	23.57	17.50	10.00	2.38
3	D3R-FSE	41.52	39.06	35.91	29.75	15.00	3.00
4	D4R-FSE	53.87	51.41	48.26	42.00	21.00	14.00
5	D5R-FSE	66.21	63.75	60.60	54.50	27.00	18.38
6	D6R-FSE	78.55	76.09	72.95	66.75	33.00	21.50
7	D7R-FSE	90.90	88.44	85.29	79.00	39.00	24.63
8	D8R-FSE	103.24	100.78	97.63	91.50	45.00	27.88
9	D9R-FSE	115.58	113.13	109.98	103.75	51.00	31.00

NOTES:

OA - OUTSIDE AIR INTAKE
 SA - SUPPLY AIR EXIT
 RA - RETURN AIR INTAKE
 EA - EXHAUST AIR EXIT

SYSTEM IS INTENDED FOR OUTDOOR USE

FOLLOW ALL APPLICABLE CODES AND
 PROPER DESIGN PRACTICES TO
 ANCHOR SYSTEM TO ROOF

D4-FSE-xSHHVH MODEL PICTURED

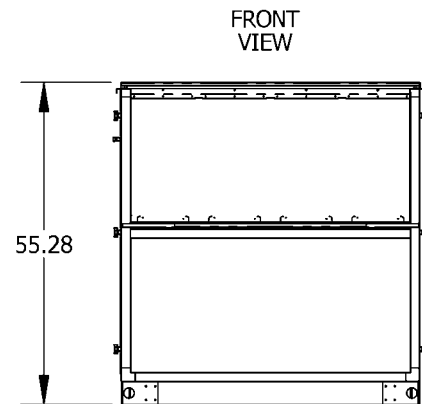
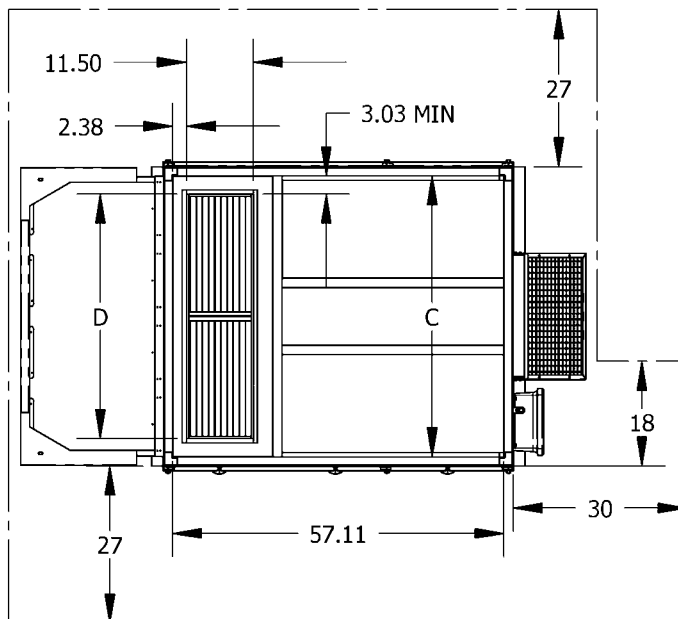
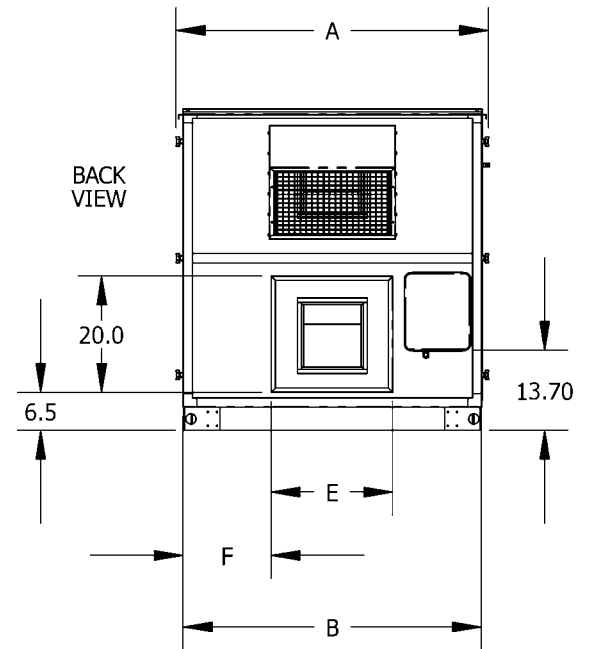
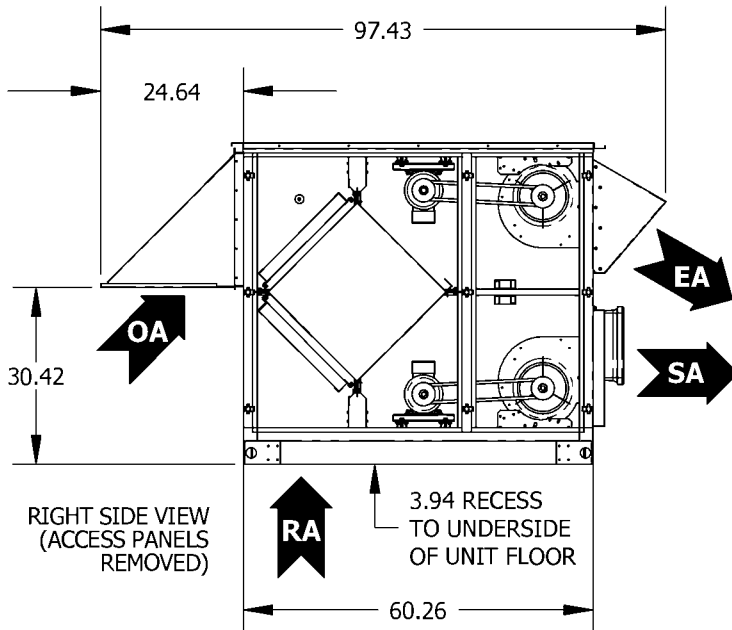

Contact Information

For sales and application information, please contact us at:

Info@ConsERV.com

or

727-375-8484 x211

For installation and warranty information, please contact us at:

Tech@ConsERV.com

or

727-375-8484 x230

Please visit us at

www.ConsERV.com

to find out more about ConsERV™ technology
and to locate your local
ConsERV™ Manufacturer's Representative

Or Write us at:

Dais Analytic Corporation
11552 Prosperous Dr.
Odessa, FL 33556

ConsERV™ products provide...

- High latent heat transfer = high performance
- Improved indoor humidity and moisture control
- Peak demand and overall energy savings
- Excellent part load performance
- No rotating parts in the component - low maintenance
- No drain pans to worry about
- Safe downsizing of HVAC plants