

D Series → Model i-FSS-xSHSHS

A standard-height indoor system with extended duct connections and integrated blowers supplying a wide range of pressures and flows. Construction is aluminum space frame with corrosion-resistant hardware and double-walled coated aluminum panels, whose closed-cell foam insulation results in a 6.3 R-value.

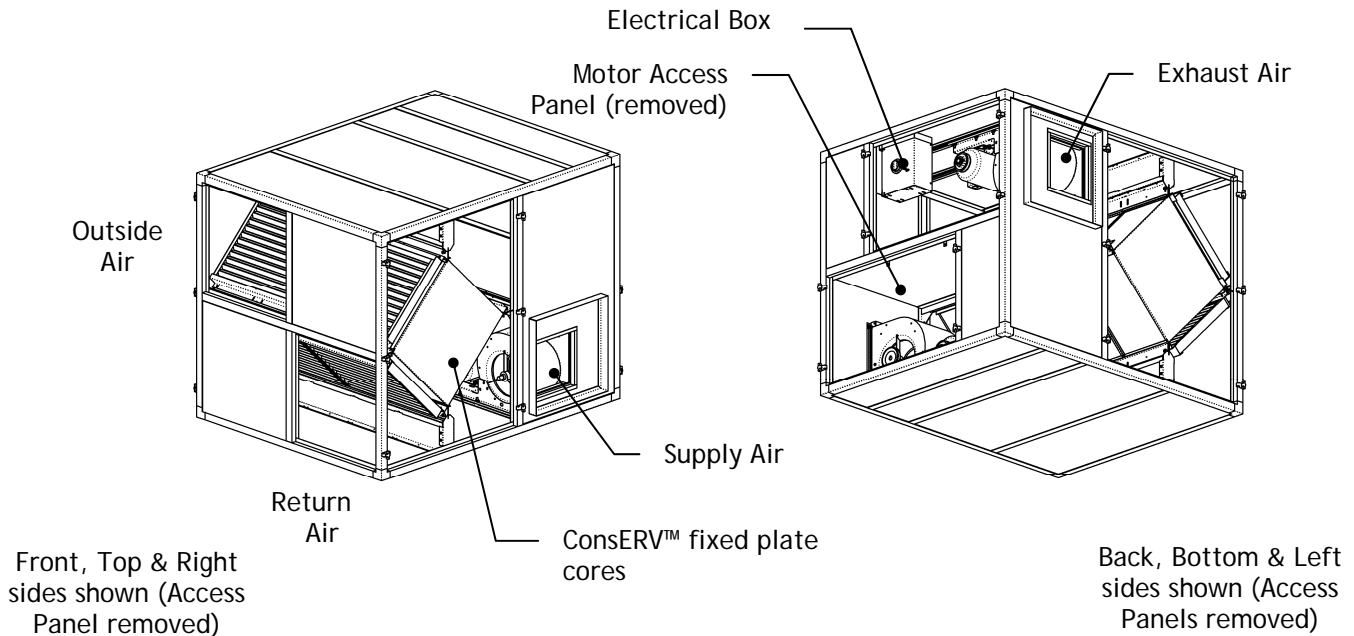

D2i-FSS -xSHSHS	ESP [in-H2O]				Max Weight = 367 lb	D3i-FSS -xSHSHS	ESP [in-H2O]				Max Weight = 459 lb
	0	0.5	1	1.5			0	0.5	1	1.5	
Airflow	600	1/2 hp	1/2 hp	1/2 hp	3/4 hp	800	1/2 hp	1/2 hp	3/4 hp	3/4 hp	
[SCFM]	900	1/2 hp	1 hp	1 hp	1.5 hp	1200	1/2 hp	3/4 hp	1 hp	1.5 hp	
	1000	1/2 hp	3/4 hp	1.5 hp	1.5 hp	1500	3/4 hp	1 hp	1.5 hp	2 hp	
	1200	1 hp	1 hp	1.5 hp	2 hp	1800	1.5 hp	1.5 hp	2 hp	2 hp	
D4i-FSS -xSHSHS	ESP [in-H2O]				Max Weight = 545 lb	D5i-FSS -xSHSHS	ESP [in-H2O]				Max Weight = 633 lb
	0	0.5	1	1.5			0	0.5	1	1.5	
Airflow	1000	1/2 hp	1/2 hp	3/4 hp	1 hp	1500	1/2 hp	3/4 hp	1 hp	1.5 hp	
[SCFM]	1800	1 hp	1.5 hp	1.5 hp	2 hp	2000	1 hp	1.5 hp	2 hp	2 hp	
	2000	1.5 hp	1.5 hp	2 hp	3 hp	2500	1.5 hp	3 hp	3 hp	3 hp	
	2400	1.5 hp	3 hp	3 hp	3 hp	3000	3 hp	3 hp	5 hp	5 hp	
D6i-FSS -xSHSHS	ESP [in-H2O]				Max Weight = 725 lb	D7i-FSS -xSHSHS	ESP [in-H2O]				Max Weight = 835 lb
	0	0.5	1	1.5			0	0.5	1	1.5	
Airflow	1800	3/4 hp	1 hp	1.5 hp	1.5 hp	2000	3/4 hp	1.5 hp	1.5 hp	2 hp	
[SCFM]	2400	1.5 hp	2 hp	3 hp	3 hp	3000	2 hp	3 hp	3 hp	3 hp	
	3000	2 hp	3 hp	3 hp	5 hp	3500	3 hp	5 hp	5 hp	5 hp	
	3400	3 hp	5 hp	5 hp	5 hp	4000	3 hp	5 hp	5 hp	7.5 hp	
D8i-FSS -xSHSHS	ESP [in-H2O]				Max Weight = 915 lb	D9i-FSS -xSHSHS	ESP [in-H2O]				Max Weight = 1003 lb
	0	0.5	1	1.5			0	0.5	1	1.5	
Airflow	3000	1.5 hp	3 hp	3 hp	3 hp	3500	2 hp	3 hp	3 hp	5 hp	
[SCFM]	3500	2 hp	3 hp	3 hp	5 hp	4000	3 hp	3 hp	5 hp	5 hp	
	4000	3 hp	5 hp	5 hp	5 hp	4500	5 hp	5 hp	5 hp	5 hp	
	4500	5 hp	5 hp	5 hp	7.5 hp	5000	5 hp	7.5 hp	7.5 hp	7.5 hp	

# CORES	MODEL #	A	B	C
2	D2i - FSS-xSHSHS	29.18	26.72	11
3	D3i - FSS-xSHSHS	41.52	39.06	17.17
4	D4i - FSS-xSHSHS	53.87	51.41	23.34
5	D5i - FSS-xSHSHS	66.21	63.75	29.51
6	D6i - FSS-xSHSHS	78.55	76.09	35.68
7	D7i - FSS-xSHSHS	90.9	88.44	41.86
8	D8i - FSS-xSHSHS	103.24	100.78	48.03
9	D9i - FSS-xSHSHS	115.59	113.13	54.2

NOTES:

SYSTEM IS INTENDED FOR INDOOR USE ONLY

OA - OUTSIDE AIR INTAKE
 SA - SUPPLY AIR EXIT
 RA - RETURN AIR INTAKE
 EA - EXHAUST AIR EXIT

OA & RA INPUTS CAN BE SWITCHED UPON REQUEST,
 CAUSING SA & EA TO REVERSE POSITIONS

D4i-FSS-xSHSHS MODEL PICTURED

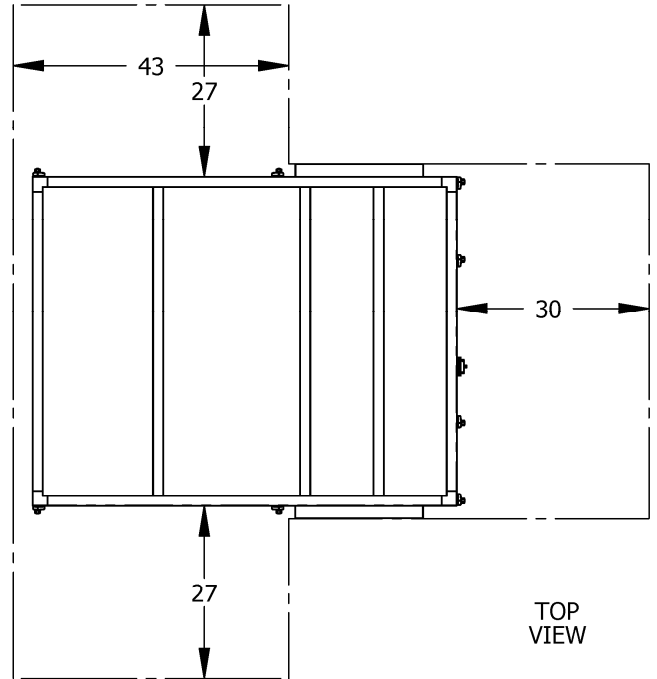
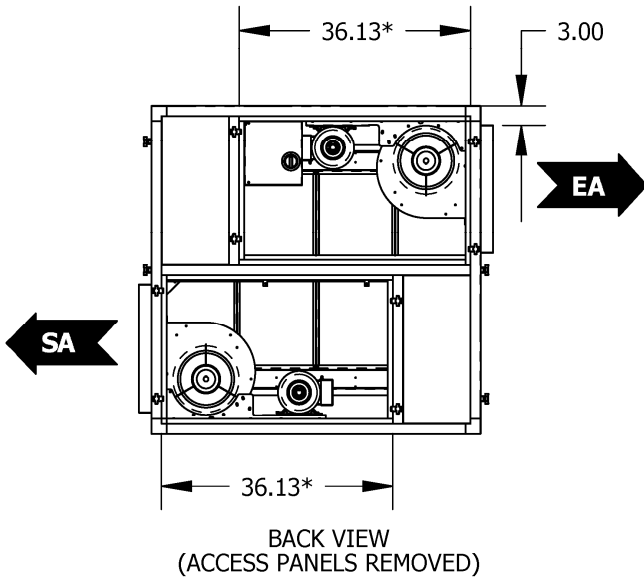

RECOMMENDED SERVICE AREA SHOWN

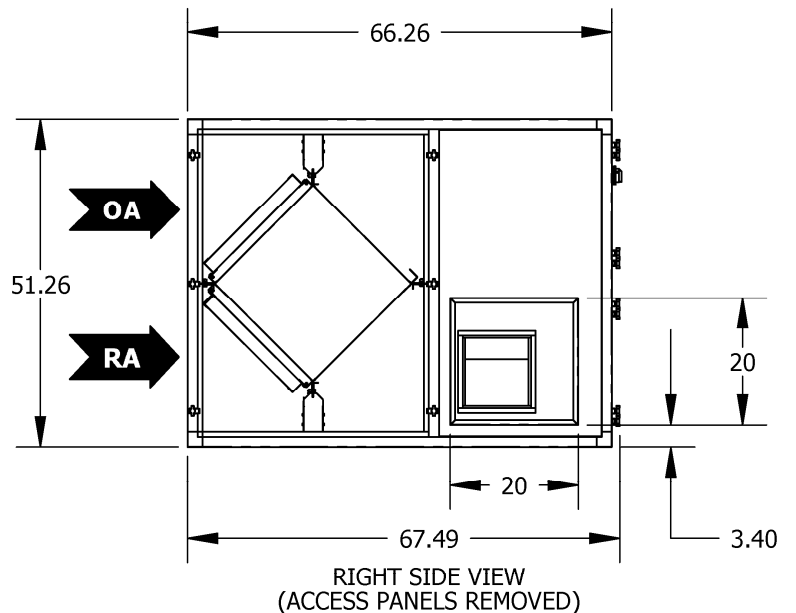
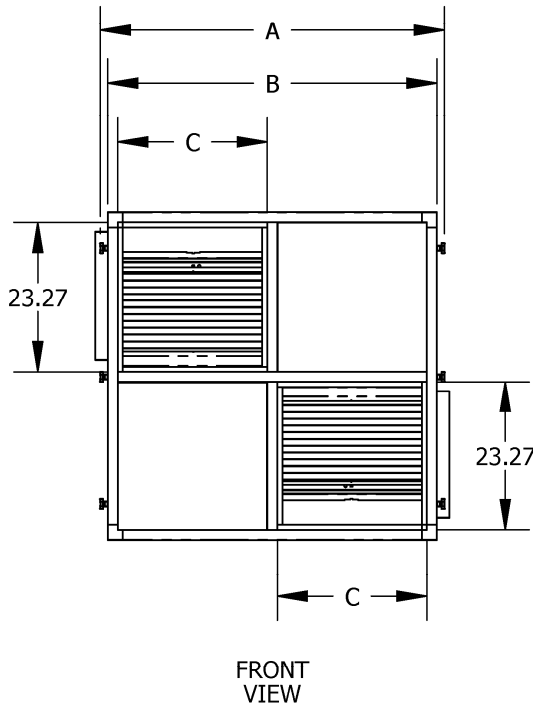

* ACCESS PANELS COVER ENTIRE WIDTH FOR D2i-FSS-xSHSHS AND D3i-FSS-xSHSHS