

D Series → Model R-FSE-xSHHHH

A rooftop system with integrated blowers designed to direct its return and supply air flows horizontally above the roof. Construction is aluminum space frame with corrosion-resistant hardware and double-walled coated aluminum panels, whose closed-cell foam insulation results in a 6.3 R-value.

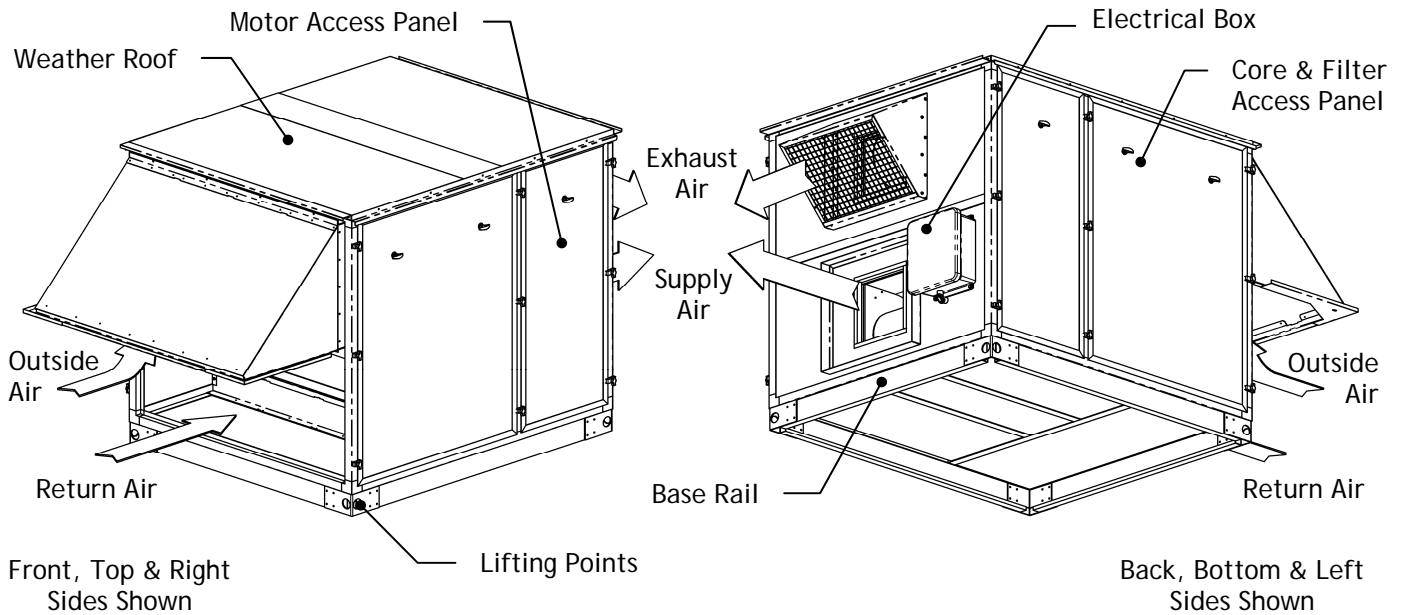

D2R-FSE -xSHHHH	ESP [in-H2O]				Max Weight = 430 lb	D3R-FSE -xSHHHH	ESP [in-H2O]			
	0	0.5	1	1.5			0	0.5	1	1.5
Airflow	600	1/2 hp	1/2 hp	1/2 hp	3/4 hp	800	1/2 hp	1/2 hp	3/4 hp	3/4 hp
[SCFM]	900	1/2 hp	1/2 hp	1 hp	1.5 hp	1200	1/2 hp	3/4 hp	1 hp	1.5 hp
	1000	1/2 hp	3/4 hp	1.5 hp	1.5 hp	1500	3/4 hp	1 hp	1.5 hp	1.5 hp
	1200	1 hp	1 hp	1.5 hp	1.5 hp	1800	1.5 hp	1.5 hp	2 hp	2 hp
D4R-FSE -xSHHHH	ESP [in-H2O]				Max Weight = 616 lb	D5R-FSE -xSHHHH	ESP [in-H2O]			
	0	0.5	1	1.5			0	0.5	1	1.5
Airflow	1000	1/2 hp	1/2 hp	3/4 hp	3/4 hp	1500	1/2 hp	3/4 hp	1 hp	1.5 hp
[SCFM]	1800	3/4 hp	1.5 hp	1.5 hp	2 hp	2000	1 hp	1.5 hp	1.5 hp	2 hp
	2000	1 hp	1.5 hp	2 hp	2 hp	2500	1.5 hp	2 hp	2 hp	3 hp
	2400	1.5 hp	2 hp	3 hp	3 hp	3000	2 hp	3 hp	3 hp	5 hp
D6R-FSE -xSHHHH	ESP [in-H2O]				Max Weight = 804 lb	D7R-FSE -xSHHHH	ESP [in-H2O]			
	0	0.5	1	1.5			0	0.5	1	1.5
Airflow	1800	1/2 hp	3/4 hp	1.5 hp	1.5 hp	2000	1/2 hp	1 hp	1.5 hp	2 hp
[SCFM]	2400	1 hp	1.5 hp	2 hp	3 hp	3000	1.5 hp	2 hp	3 hp	3 hp
	3000	1.5 hp	3 hp	3 hp	3 hp	3500	2 hp	3 hp	3 hp	5 hp
	3400	2 hp	3 hp	5 hp	5 hp	4000	3 hp	3 hp	5 hp	5 hp
D8R-FSE -xSHHHH	ESP [in-H2O]				Max Weight = 980 lb	D9R-FSE -xSHHHH	ESP [in-H2O]			
	0	0.5	1	1.5			0	0.5	1	1.5
Airflow	3000	1.5 hp	1.5 hp	3 hp	3 hp	3500	1.5 hp	2 hp	3 hp	5 hp
[SCFM]	3500	2 hp	3 hp	3 hp	5 hp	4000	3 hp	3 hp	3 hp	5 hp
	4000	3 hp	3 hp	5 hp	5 hp	4500	3 hp	5 hp	5 hp	5 hp
	4500	5 hp	5 hp	5 hp	5 hp	5000	5 hp	5 hp	7.5 hp	7.5 hp

CORES	MODEL #	A	B	C	D	E	F
2	D2R-FSE	29.18	26.72	23.57	23.57	10.00	2.38
3	D3R-FSE	41.52	39.06	35.91	35.91	15.00	3.00
4	D4R-FSE	53.87	51.41	48.26	48.26	21.00	14.00
5	D5R-FSE	66.21	63.75	60.60	60.60	27.00	18.38
6	D6R-FSE	78.55	76.09	72.95	72.95	33.00	21.50
7	D7R-FSE	90.90	88.44	85.29	85.29	39.00	24.63
8	D8R-FSE	103.24	100.78	97.63	97.63	45.00	27.88
9	D9R-FSE	115.58	113.13	109.98	109.98	51.00	31.00

NOTES:

- OA - OUTSIDE AIR INTAKE
- SA - SUPPLY AIR EXIT
- RA - RETURN AIR INTAKE
- EA - EXHAUST AIR EXIT

SYSTEM IS INTENDED FOR OUTDOOR USE

FOLLOW ALL APPLICABLE CODES AND PROPER DESIGN PRACTICES TO ANCHOR SYSTEM TO ROOF AND CURB

D4R-FSE-xSHHHH MODEL PICTURED

